



SERVICE PARTS LIST

BULLETIN NO.
54-10-4033

SPECIFY CATALOG NO. AND SERIAL NO. WHEN ORDERING PARTS		REVISED BULLETIN 54-10-4032	DATE May '89
SINGLE SPEED HOLE HAWG			
CATALOG NO. 1670-1	STARTING SERIAL NO. 472-24725	WIRING INSTRUCTION 58-01-0626	

EXAMPLE:



Component Parts (Small #) Are Included
When Ordering The Assembly (Large #).

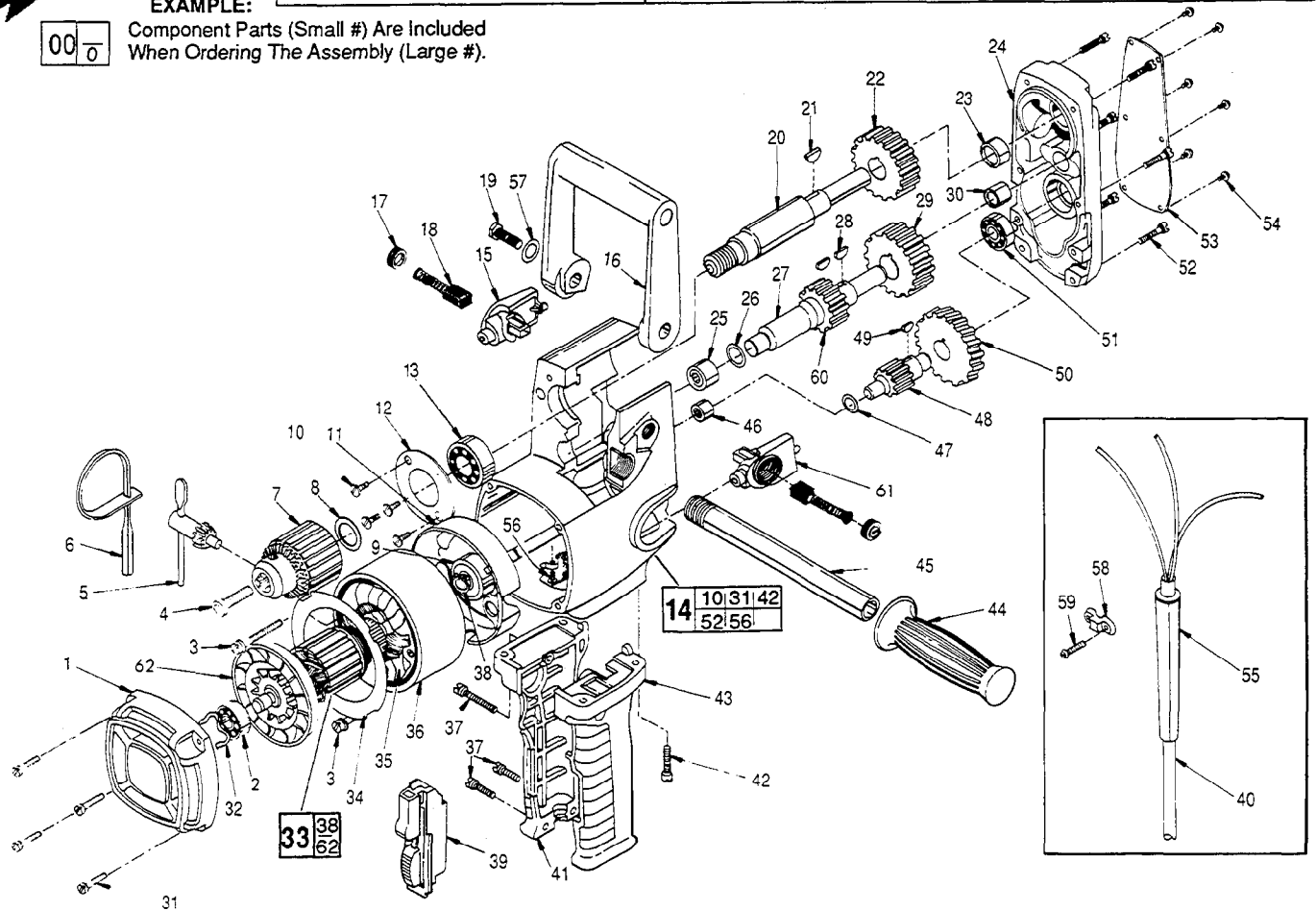

FIG.	PART NO.	DESCRIPTION OF PART	NO. REQ.	FIG.	PART NO.	DESCRIPTION OF PART	NO. REQ.
1	28-50-6235	Bearing Support Housing	(1)	36	23-16-0425	Field Insulator	(1)
2	02-04-0911	Ball Bearing	(1)	37	06-82-7326	8-16x1" Plastite Screw	(3)
3	06-95-3285	8-16x1-13/16" Plastite Pan Hd. Screw	(2)	38	34-60-0827	Retaining Ring	(1)
4	06-75-3150	1/4-20x1" L.H. Soc. Hd. Cap Screw	(1)	39	23-66-1020	Switch	(1)
5	48-66-3280	Chuck Key	(1)	40	22-64-0121	Cord Set	(1)
6	48-66-4040	Key Holder	(1)	41	31-44-1440	R.H. Drill Handle	(1)
7	48-66-1381	Chuck	(1)	42	06-82-5358	12-24x3/4" Pan Hd. Taptite Screw	(4)
8	45-88-0330	Chuck Spacer Washer	(1)	43	31-44-1445	L.H. Drill Handle	(1)
9	02-04-1050	Ball Bearing	(1)	44	43-62-0246	Handle Grip	(1)
10	06-81-5502	8-32x3/8" Comb. Phil. Hd. Sem.	(4)	45	43-62-0122	Pipe Handle	(1)
11	31-55-0065	Coil Shield	(1)	46	02-50-2020	Needle Bearing	(1)
12	44-66-5241	Bearing Retainer Plate	(1)	47	45-88-7100	Fiber Thrust Washer	(1)
13	02-04-1700	Ball Bearing	(1)	48	36-66-1310	1st. Intermediate Pinion	(1)
14	28-50-6127	Motor Housing Assembly	(1)	49	06-42-0800	Woodruff Key	(1)
15	22-22-1350	R.H. Brush Holder Assembly	(2)	50	32-42-1301	1st. Intermediate Gear	(1)
16	31-44-1100	Spade Handle	(1)	51	02-04-0910	Ball Bearing	(1)
17	23-44-0220	Brush Retaining Cap	(2)	52	06-81-6350	8-32x1" Fil. Hd. Gear Case Cover Screw	(6)
18	22-18-0670	Carbon Brush Assembly	(2)	53	12-98-7045	Nameplate	(1)
19	06-75-0500	3/8-16x1" Hex Hd. Spade Handle Screw	(1)	54	06-81-8400	4-40x1/4" Rd. Hd. Nameplate Screw	(6)
20	38-50-5070	Spindle	(2)	55	44-76-0150	Cord Protector	(1)
21	06-42-2000	Woodruff Key	(1)	56	06-81-8625	6-32 x 1/4" Ground Screw	(1)
22	32-75-2210	Spindle Gear	(1)	57	45-88-0605	Flat Washer	(2)
23	02-50-3170	Needle Bearing	(1)	58	31-17-0156	Cord Clamp	(1)
24	28-20-1123	Gear Case Cover	(1)	59	06-82-7270	8-16x5/8" Pan Hd. Slt. Torx Plastite Screw	(2)
25	02-50-3180	Needle Bearing	(1)	60	32-40-1970	2nd Intermediate Gear	(1)
26	45-88-7095	Fiber Thrust Washer	(1)	61	22-22-1355	L.H. Brush Holder Assembly	(1)
27	36-66-4400	2nd. Intermediate Shaft	(1)	62	22-84-0660	Fan Assembly	(1)
28	06-42-1900	Woodruff Key	(2)		10-98-5986	Caution Label	(1)
29	32-44-1190	2nd. Intermediate Gear	(1)				
30	02-50-2750	Needle Bearing	(1)				
31	06-81-6202	8-32x5/8" Fil. Hd. Brg. Support Hsg. Screw	(4)				
32	45-88-7110	Spring Washer	(1)				
★ 33	16-50-0076	Armature Assembly	(1)				
34	42-14-0150	Baffle	(1)				
★ 35	18-50-0076	Field Assembly	(1)				

FIG. LUBRICATION
24 4oz. Type "E" Grease, No. 49-08-4121.
Prelube all needle bearings with Type "E" Grease, No. 49-08-4121.

MILWAUKEE ELECTRIC TOOL CORPORATION
13135 W. LISBON RD., BROOKFIELD, WI 53005