

1. PRODUCT NAME

Hitachi Charger, Model UC 9SD

2. MARKETING OBJECTIVE

The Model UC 9SD is an inexpensive 9.6 V-only charger that has been developed to promote sales of our low-cost cordless tools. It is designed to charge the Hitachi types EB 9S, FEB 9 and FEB 9S rechargeable batteries.

3. APPLICATIONS

Charging of Hitachi 9.6 V Rechargeable Batteries

Applicable Batteries EB 9S [9.6 V 1300 mAh (4-terminal)]
 FEB 9 [9.6 V 1300 mAh (3-terminal)]
 FEB 9S [9.6 V 1400 mAh (4-terminal)]

4. SELLING POINTS

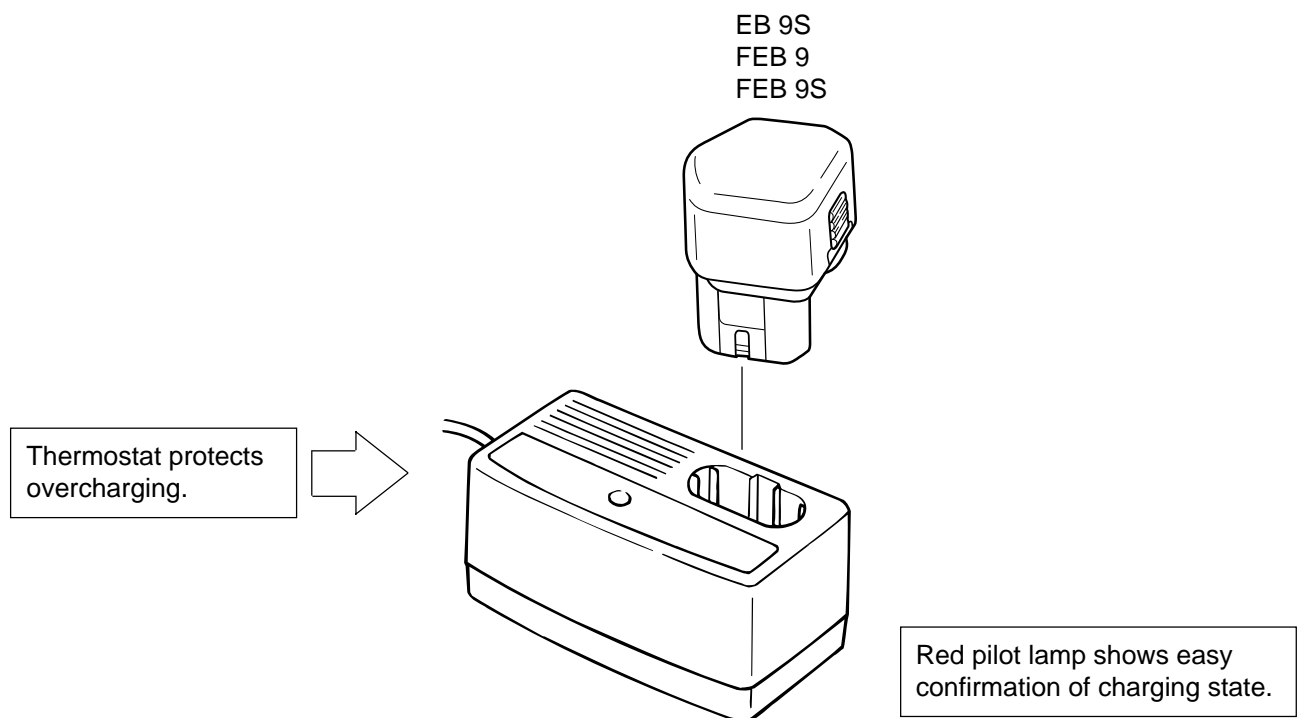

5. SPECIFICATIONS

5-1. Specifications

Item	Descriptions
Power supply	Frequency: 50 Hz, 60 Hz Voltage: 110 V, 120 V, 220 V, 230 V, 240 V
Input capacity	30 W
Voltage drop method	Isolating transformer with center tap
Rectifying method	Full wave rectification
Overcharging protection system	A thermostat monitors the storage battery surface temperature. When a specified temperature is detected, indicating that charging is completed, an electronic control circuit turns off the power to prevent overcharging.
Charging indication method	Pilot lamp indication: During charging: On Charging completed: Off
Charging voltage	9.6 V
Charging current	1.55 A
Charging time at 20 °C (at 68 °F)	Approx. 55 minutes EB 9S Approx. 85 minutes EB 9B Approx. 55 minutes FEB 9 Approx. 60 minutes FEB 9S
Product weight	1.2 kg (2.6 lbs.)
Operating temperature	10 °C – 40 °C (50 °F – 104 °F)

5-2. Comparisons with Similar Product

Model	Unit	HITACHI	HITACHI
		UC 9SD	UC 12SD
Charging time	min.	60 (FEB 9S storage batteries)	60 (FEB 12S storage batteries)
Charging voltage	V	9.6	12
Charging current	A	1.55	1.55
Input capacity	W	30	51
Applicable ambient temperature range	°C (°F)	10 – 40 (50 – 104)	10 – 40 (50 – 104)
Charging completion system		Thermostat	Thermostat
Outer dimensions	mm (in)	181 x 87 x 80 (7-1/8 x 3-7/16 x 3-5/32)	181 x 87 x 80 (7-1/8 x 3-7/16 x 3-5/32)
Product weight	kg (lbs.)	1.2 (2.6)	1.5 (3.3)

6. PRECAUTIONS IN SALES PROMOTION

6-1. Safety Instructions

In the interest of promoting the safest and most efficient use of the Model UC 9SD Charger by all of our customers, it is very important that at the time of sale the salesperson carefully ensures that the buyer seriously recognizes the importance of the contents of the Handling Instructions, and fully understands the precautions listed on the Caution Plate and Nameplate attached to the Charger.

6-1-1. Handling Instructions

Salespersons must be thoroughly familiar with the contents of the Handling Instructions in order to give pertinent advice to the customer.

(1) Never charge Hitachi 7.2 V rechargeable battery with the Model UC 9SD Charger:

Attempting to charge 7.2 V rechargeable battery can cause the thermal fuse of the Charger transformer or the electric fuse on the Printed Circuit Board to blow. Strictly avoid charging 7.2 V battery.

(2) Connect the Charger to an AC power outlet only:

Use of any other power source (DC outlet, engine-powered generator, etc.) will cause the Charger to overheat and burn out.

(3) Do not use any voltage increasing equipment (voltage regulator, etc.) between the power supply and the Charger:

If the Charger is used with voltage over and above that indicated on the unit, it will not function properly.

(4) Charge at a temperature range of 10 °C – 40 °C (50 °F – 104 °F):

The Charger and storage batteries each contain a special charging circuit. Be sure to instruct the customer to charge at a temperature range of 10 °C – 40 °C (50 °F – 104 °F). In temperatures below 10 °C (50 °F), even if the battery is fully charged, the thermostat will not function causing the battery to overcharge dangerously. In temperatures over 40 °C (104 °F), batteries will not reach a full charge. The optimum temperature for charging is around 20 °C (68 °F) to 25 °C (77 °F) (room temperature).

(5) Do not use the Charger for repeated charging:

In very hot locations, if two or more batteries are charged successively, the temperature of the Charger may rise too high and cause the Charger to fail. Instruct the customer to wait for at least 15 minutes before charging a second battery. Particular care is necessary in summer.

(6) Do not insert foreign objects into the air vents on the Charger:

The Charger case is equipped with air vents to protect the internal electronic components from overheating. Instruct the customer that foreign materials, such as metallic or flammable objects, are not to be dropped or inserted into the air vents. This might cause electrical shock, fire or other serious hazards.

(7) Do not attempt to disassemble the Charger:

Incorrect parts replacement and/or wiring will cause malfunctions which could result in fire or other hazards. Instruct the customer to bring the charger to an authorized service center in the event that repair or replacement is necessary.

6-2. Points Requiring Special Attention During Sales Promotion

The customer should be advised of the following points during sales promotion of the Charger.

6-2-1. Charging May Not Be Possible When the Storage Battery Temperature Is High

Charging may not be possible if the temperature of the battery is 40 °C (104 °F) or higher after it has been exposed to direct sunlight for a long time or immediately after it has been used. In such cases, the customer should be advised to place the battery in the shade with good airflow, and allow it to cool sufficiently prior to recharging. This condition is common to all existing chargers (both Hitachi's and competitor's models) which employ temperature sensitive devices to terminate charging. The cooling period required before charging varies from a few minutes to about 30 minutes, depending on the length of time the battery was used and the ambient temperature.

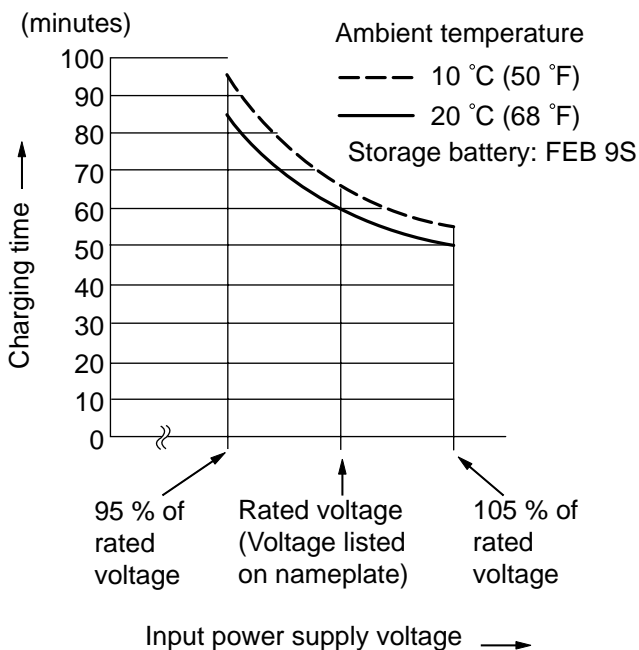

6-2-2. If the Ambient Temperature or Power Supply Voltage Is Low, Charging Time May Be Longer

The charging time for UC 9SD is greatly influenced by the ambient temperature and input power supply voltage.

The relationship between input power supply voltage and charging time is shown in Fig. 1.

If the input power supply voltage is high, charging takes less time; if low, it takes more time. Be sure to advise the customer to charge the batteries at the ambient temperature specified in the Handling Instructions and at the rated voltage listed on the nameplate.

Fig. 1 Relationship between input power supply voltage and charging time

7. REFERENCE MATERIAL

7-1. Model UC 9SD Structure

- (1) The outer casing consists of Case (A) and Case (B). A light bar for the Pilot Lamp is built into Case (A).
- (2) Electronic components which provide rapid charging and prevent overcharging are mounted on the Printed Circuit Board.

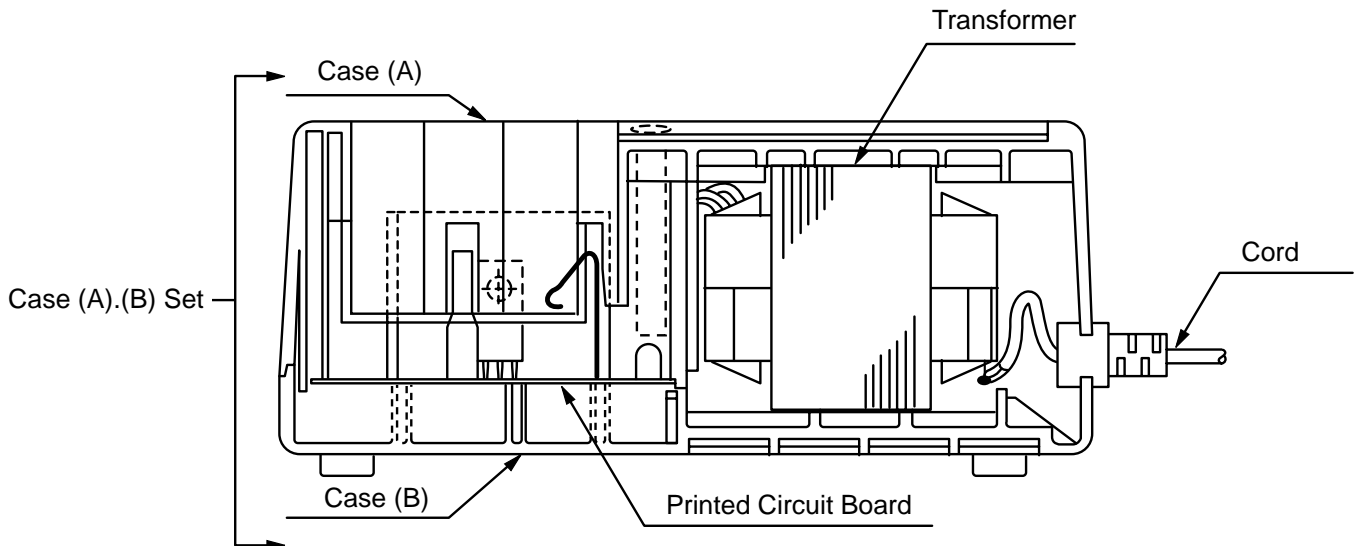

Fig. 2

8. PRECAUTIONS IN DISASSEMBLY AND REASSEMBLY

The **[Bold]** numbers in the descriptions below correspond to the item numbers in the parts list and exploded assembly diagram.

8-1. Disassembly

- (1) Remove the four Screws (Plastic Tie) D4 x 20 **[5]**, and take off Case (B).
- (2) When the Transformer **[9]** is lifted upward, the Printed Circuit Board **[4]** and the Cord **[10]** can be removed together.
- (3) To separate the Printed Circuit Board **[4]**, Transformer **[9]** and Cord **[10]**, melt their soldered connections with a soldering iron at the points marked 1, 2, 3, 4 and 5 in Fig. 3. As excessive heat may damage the material of the Printed Circuit Board, use of the soldering iron should be limited to less than three seconds at one time.

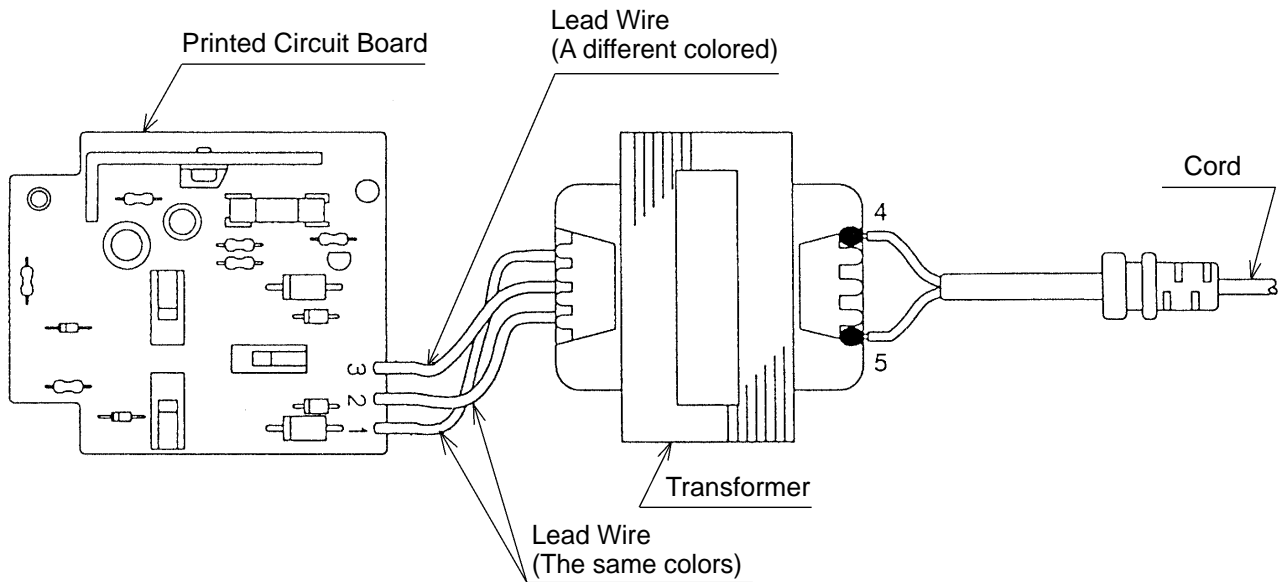

Fig. 3

8-2. Reassembly

Reassembly can be accomplished by following the disassembly procedures in reverse. However, particular attention should be given to the following points.

- (1) Solder the lead wires of the Cord [10] after passing their stripped end portions through the holes of the Printed Circuit Board [4] and bending them securely.
- (2) Be very careful to ensure that the lead wires are not pinched between Case (A) and Case (B) during reassembly.

8-3. Confirmation after Reassembly

On completion of reassembly, confirm the following items.

(1) Confirmation of Charging State

Confirm that the Pilot Lamp on the Charger goes on.

Confirm that the Pilot Lamp goes off approximately 60 minutes after the start of charging (when FEB 9S is charged at 20 °C (68 °F)).

(2) Measure the Insulation Resistance and Conduct a Dielectric Strength Test

Insulation Resistance: 10 megohms or more between the plug blade of Cord and the Nameplate or fastening screws on the Case with DC 500 V Megohm Tester.

Dielectric Strength Test:

- (a) Between the plug blade of the Cord and charging terminal blade
- (b) Between the plug blade of the Cord and Nameplate or fastening screws on the Case

The dielectric strength test should be conducted at the following voltage:

Nameplate	Test voltage
110, 120, 220, 230, 240 V	AC 1,250 V (1 minute)

(CAUTION) Measurement of insulation resistance and the dielectric strength test must be conducted between the plug blade and the nameplate or fastening screws on the case, and between the plug blade and the charging terminal blade. Under no circumstances should tests be conducted between both blades of the plug, or both blades of the charging terminal, which may cause burnout of the Charger.

9. TROUBLESHOOTING GUIDE

9-1. Failure During Charging

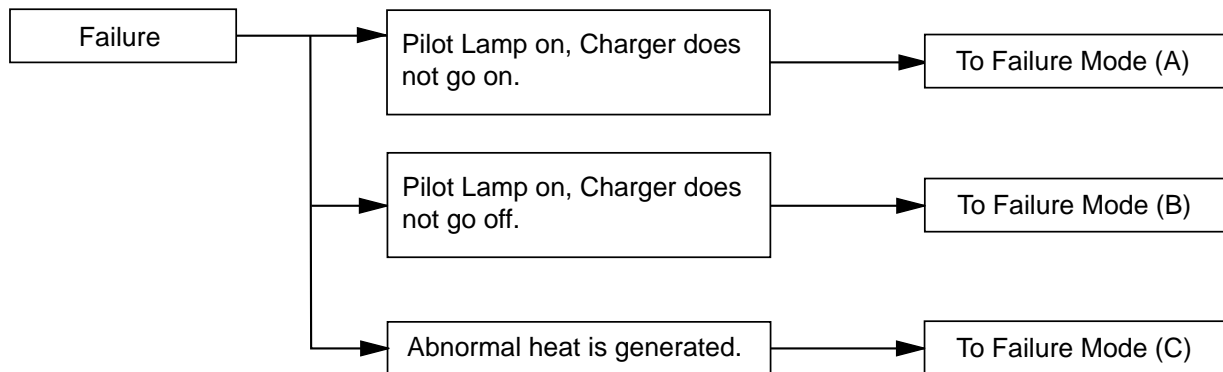

(1) Failure Mode (A) Steps and Repair Procedures

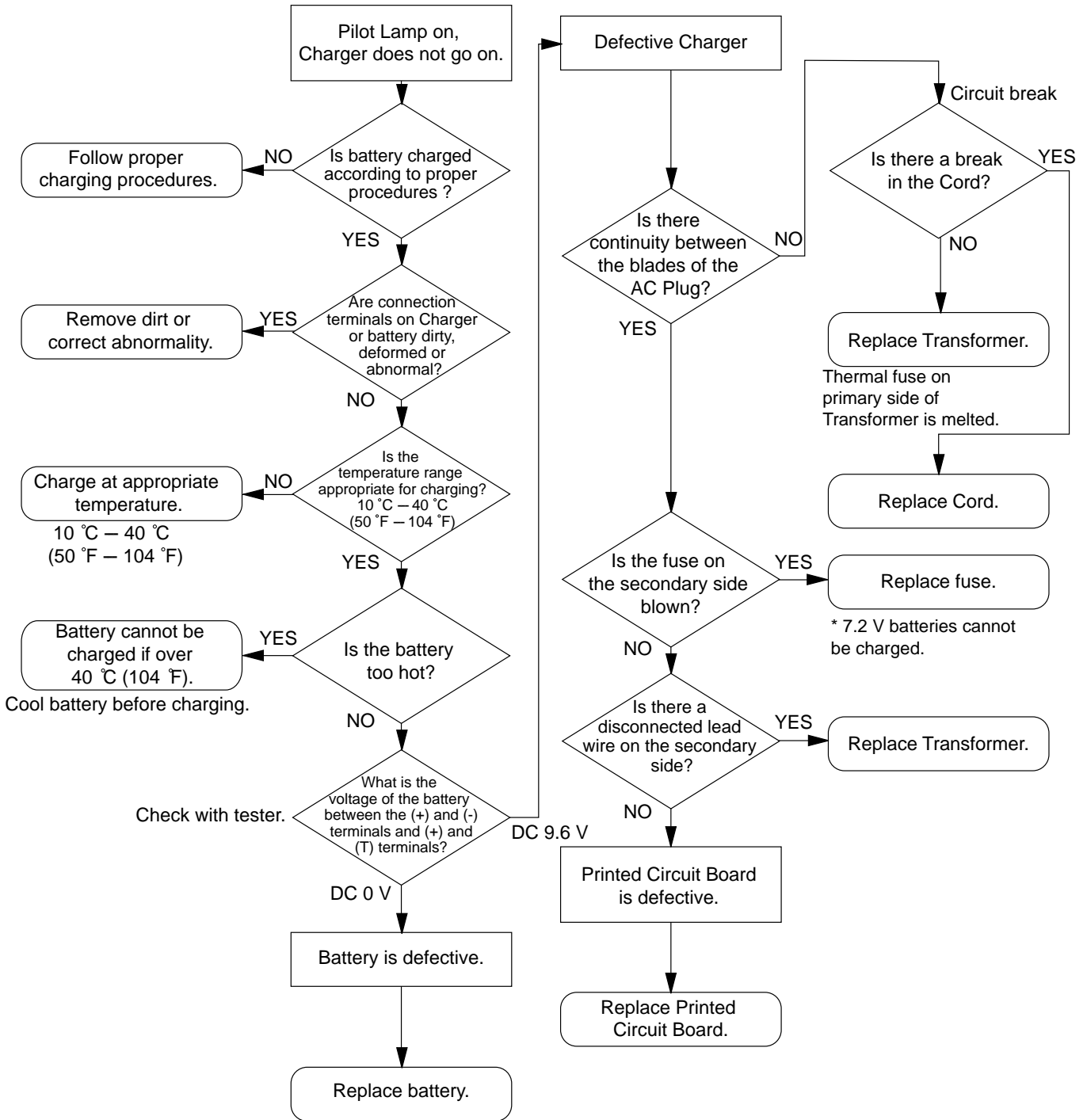

(2) Failure Mode (B) Steps and Repair Procedures

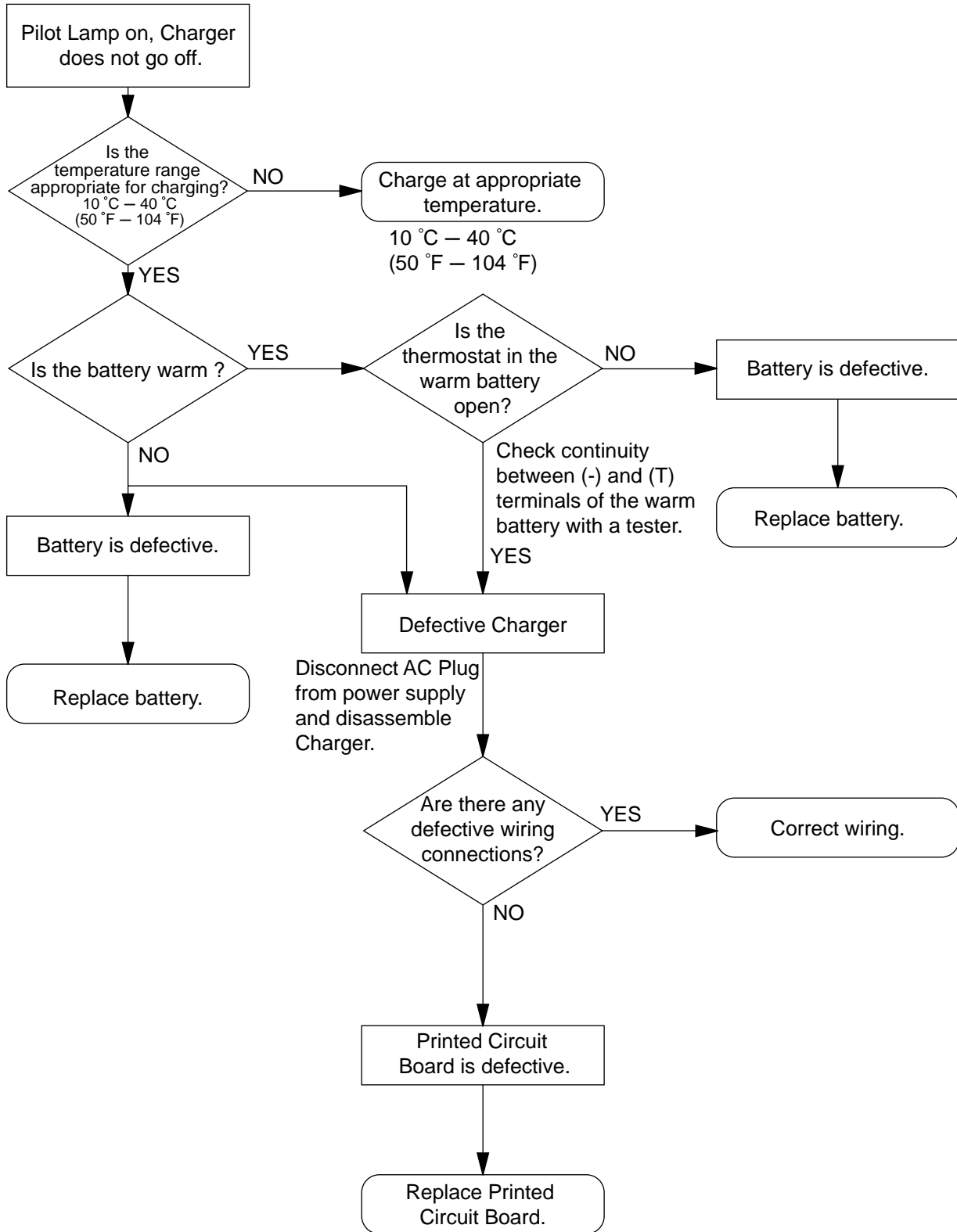

(3) Failure Mode (C) Steps and Repair Procedures

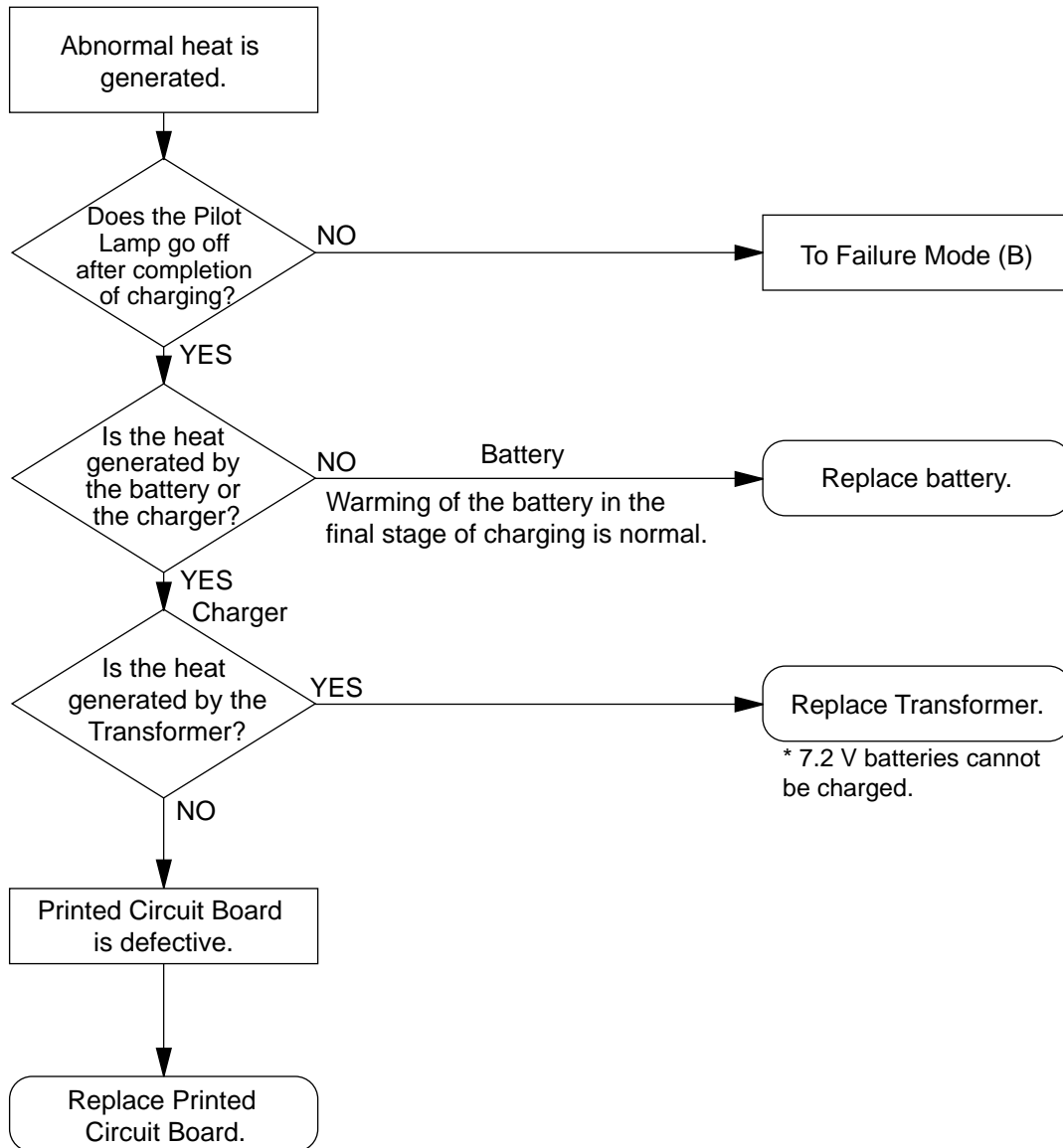

10. STANDARD REPAIR TIME (UNIT) SCHEDULES

MODEL	Variable		10	20	30	40	50	60 min.
	Fixed							
UC 9SD		Work Flow						
		General Assembly	Light Bar Fuse (6.3 A)	Case (A).(B) Set Printed Circuit Board Transformer Cord				

Assembly Diagram for UC 9SD

