

T ECHNICAL INFORMATION

Models No. ▶ 5008NB

Description ▶ 210MM (8 1/4") CIRCULAR SAW

CONCEPTION AND MAIN APPLICATIONS

The machine is an electric circular saw, developed as one of 5007 series, with a bigger aluminium base for steady cutting work.

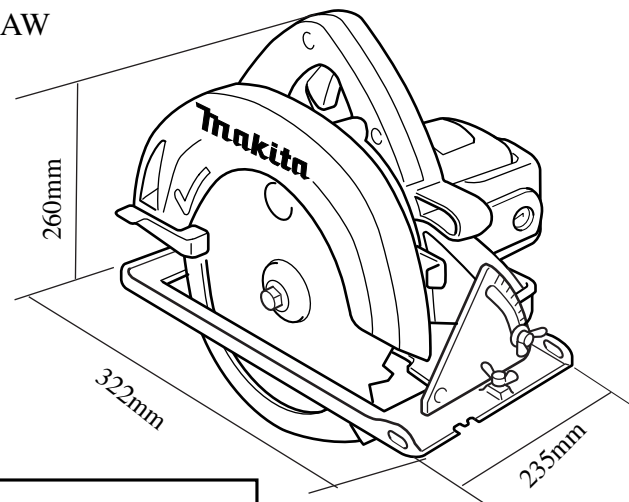

► Specifications

Motor		Series commutator motor					
Voltage (V)		100	115	200	220	230	240
Current (A)		15	13	7.5	7.0	6.5	6.5
Cycle (Hz)		50/60Hz	50/60Hz	50/60Hz	50/60Hz	50/60Hz	50/60Hz
Continuous Rating (W)	Input	1400W	1400W	1400W	1400W	1400W	1400W
	Output	870W	870W	870W	870W	870W	870W
Max. Output (W)		1700W	1700W	1700W	1700W	1700W	1700W
No Load Speed (rpm)		5200					

► Capacity

Diameter of using saw blade	210mm(8 1/4"), Inner dia. 16mm (5/8")
Cutting depth	90° 0~72.5mm 45° 0~56mm
Total length(size)	322mm
Net Weight	5.2kg
Power supply cord	2.5m
Insulation class	Double insulation structure

► Equipment

Rip fence
Spanner 13

► Optional Accessories

Combination saw blade210 (same as the item attached to Machine)
TCT saw blade210

► Features and Benefits

- (1) Very light and compact, comparing to equivalent items of other manufacturers.
- (2) Owing to equipment of Switch available for both direct/alternating currents, you can use the Machine with direct current source.
- (3) As peeping window of Blade edge is big, you can decide the position of cutting easily.
- (4) With Double insulation structure, it is safe electrically,
- (5) Bevel cut from 0° to 45° is available.

► Assembly/Disassembly

Please pay attention to the following matter, when you repair the machine.

* Fastening of square neck head bolt has to be so adjusted that the angle of lever plate comes to the following position illustrated below.

