

For Models ▶ DC1801

Description ▶ Battery Charger

CONCEPTION AND MAIN APPLICATIONS

1. This charger can charge MAKITA Ni-MH batteries (NICKEL METAL HYDRIDE BATTERY) and MAKITA Ni-Cd batteries. This charger can charge all voltages from 7.2V to 18V.
2. This charger has a trickle charging function, by which fully-charged batteries will be kept fully charged while left in charger.
3. Even a heated battery after use can be left in the charger. This charger automatically starts charging the battery after cooled down.
4. Charging condition is displayed by green or red light. The light indicates ready to charge, charging, charging complete, delay charge (too hot) and defective battery.

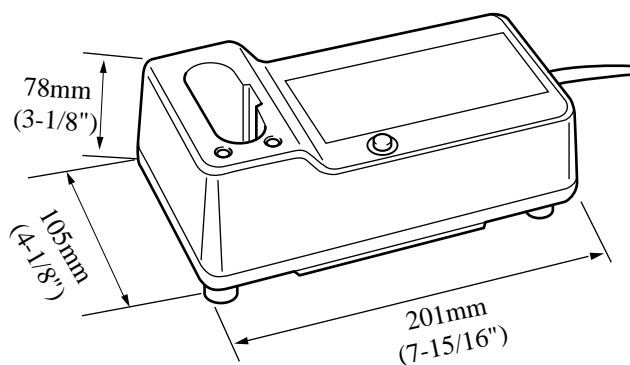

► Specifications

Input voltage	120V, 220-240V, 230-240V	
Input	60W	
Output voltage	DC 7.2V, 9.6V, 12V, 14.4V, 18V	
Output current(A)	DC 2.1A	
Charging time	40 min.	for 1.3Ah battery (Battery 7000, 9000, 9100, 9100A, 9120, 1200, 1200A, 1210, 1220)
	50 min.	for 1.7Ah battery (Battery 7001, 9001, 9101, 9101A, 1201, 1201A)
	60 min.	for 2.0Ah battery (Battery 7002, 9002, 9102, 9102A, 9122, 1202, 1202A, 1222, 1422, 1822)
	65 min.	for 2.2Ah battery (Battery 7033, 9033, 9133, 1233, 1433, 1833)
Net weight	0.48kg (1.06lbs)	
Cord length(m)	2m (6.6ft)	

► Features and benefits

How to charge

1. Computer control
Computer deducts the completion of charging and controls charging current.
2. Switching power source method
First, input electricity is converted to high-frequency current of approximately one hundred kHz. And the voltage is transformed into the battery voltages by the high-frequency transformer.
The charger can be designed smaller and lighter than using the general transformer with this method.
3. Constant current charging
Charging current will be kept stable, so that the change of the battery can be detected.
(See the "1. minus delta V" of Method of stop charging)
4. Trickle charging function
See "CONCEPT AND MAIN APPLICATIONS" .

Method of stop charging

DC1801 has four different methods of stop charging.

Each of methods will work individually. (whichever method comes first will stop charging.)

1. minus delta V
Charging will be stopped by the detection of the drop of the battery voltage.
See (1) of chart below.
2. delta T
Charging will be stopped by the detection of the rise of the battery temperature.
See (2) of chart below. (for the batteries with 4 terminals only)
3. T
Charging will be stopped by the detection of the upper limit of the battery temperature.
See (2) and (3) of chart below.
The upper limits of the battery temperature are 45 degree C. for 1.3Ah batteries and 60 degree C. for 1.7, 2.0 and 2.2Ah batteries.
4. Timer
Charging will be stopped by the length of charging time as a supplementary method.

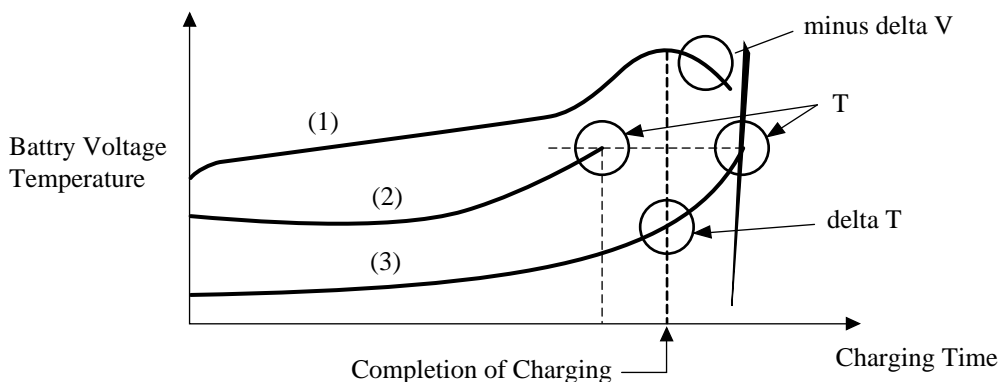

Line (1) shows Battery Voltage.

Line (2) shows Battery Temperature of Heated Battery.

Line (3) shows Battery Temperature of Normal Battery. Charging is stopped at delta T.

Note : Comparing line (2) and line (3) , you can find the point of stop charging before completion of charging on line (2).

► Repair

circuit board

In case of damage of the varistor or fuse, please carry out the repairing as follows, then it is not required to change the circuit board.

1. How to check the damaged varistor

In case of the following condition, the varistor has to be changed.

- 1) The surface of varistor is broken.
- 2) The circuit board near varistor or the inside of charger case is sooty.
- 3) In case of breakage of fuse, also the varistor can be defective.
- 4) In case of connection of the fast charger with double voltage power source of rated voltage for the fast charger, the varistor can be damaged.
- 5) However, the circuit board has to be changed in case that only the fuse is damaged. (the varistor is in order)

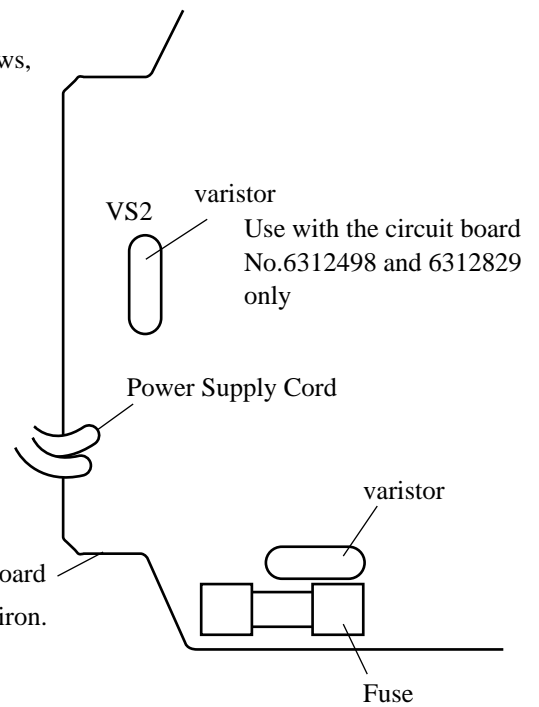

1. How to dismount and mount the varistor

- 1) Take off damaged varistor soldered on the circuit board, with soldering iron.
- 2) Solder the new varistor on the circuit board with soldering iron, and then the extra lead wire from the varistor has to be cut by nipper.

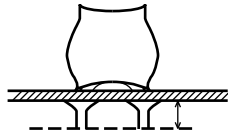

The overhang length must be under 3mm

1. How to dismount and mount the fuse

- 1) Take off damaged fuse soldered on the circuit board, with soldering iron.
- 2) Solder the new fuse on the circuit board with soldering iron, and then the extra lead wire from the fuse has to be cut by nipper.

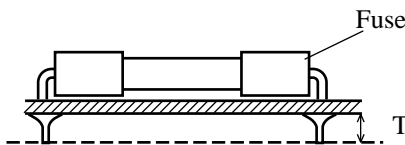

The overhang length must be under 3mm by cutting the extra.

► Interchangeability

The following spare parts have an interchangeability with the existing DC1411.

Vinyl Cord
Tapping Screw M4 x 25
Varistor
Fuse (only P/N 652727-4)

The spare parts other than the above mentioned have no interchangeability.