

# TECHNICAL INFORMATION



NEW TOOL

P 1 / 9

Models No. ▶ 6827

Description ▶ Screwdriver

## CONCEPTION AND MAIN APPLICATIONS

These new models have been developed from Model 6823 for matured line-up of Makita Screwdrivers.

While they have the same powerful motor and the ergonomic designed body as Model 6823 ;

**6827** features the same 6 stage torque control system as Model 6805BV for effective screwdriving of various screws.

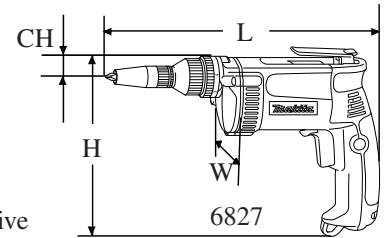

Dimensions : mm ( " )	
Length (L)	304 (12)
Height (H)	218 (8-5/8)
Width (W)	70 (2-3/4")
Center height (CH)	23.3 (15/16")

## ► Specification

Voltage (V)	Current (A)	Cycle (Hz)	Continuous Rating (W)		Max. Output(W)
			Input	Output	
120	6.5	50/60	(710)	340	590
220	2.7	50/60	570	260	570
230	2.6	50/60	570	260	570
240	2.5	50/60	570	260	570

No load speed (min-1=rpm)	0 - 2,500
Driving shank : mm ( " )	6.35 (1/4)
Max. driving capacity	Self drilling screw 6mm (#14) Hex screw 6mm (#14) Machine screw M8 (5/16")
Fastening torque adjustment	Yes (6 stages)
Fastening depth adjustment	Yes
Reverse switch	Yes
Retractable belt clip	Yes
Soft-grip handle	Yes
Protection from electric shock	by double insulation
Cord length : m (ft)	2.5 (8.2) / 4.0m (13.1) for Europe
Weight : Kg (lbs)	1.8 (4.0)

## ► Standard equipment

\* Plastic case ..... 1 pc.

< Note > The standard equipment for the tool shown may differ from country to country.

## ► Optional accessories

\* Various philips bits and socket bits  
\* Various magnetic socket bits

\* Front cap 12  
\* Front cap 15.5  
\* Front cap 1/4  
\* Front cap 5/16  
\* Front cap 3/8  
\* Front cap 5/16

**Model 6827**

**Features Fastening Torque Control**

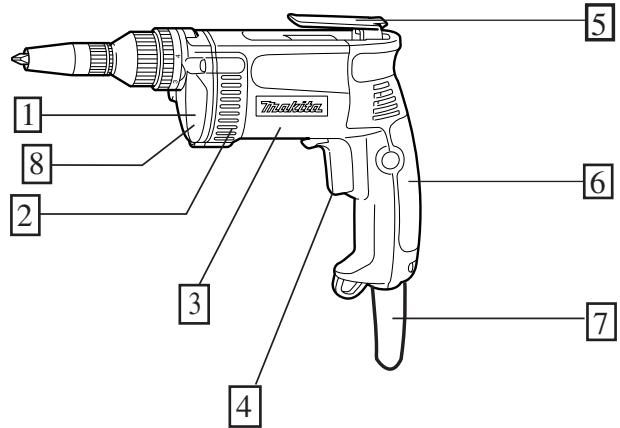

1 Solid Aluminum Gear Housing

2 Air Outlet Designed for Operator's Comfort  
Cooling air is exhausted towards the bit side for comfortable operation.

3 Slim but Powerful 570W Motor

4 Large Switch with Reversing Lever and Lock-Off Button  
Convenient for single-handed operation.

5 Belt Clip is Retractable into Motor Housing.

6 Ergonomic Designed Soft Grip Handle  
Presses the machine just along the spindle axis for effective screwdriving.

7 Durable Cord Guard against Frequent Inflection

8 Low noise and suppressed vibration thanks to pin type silent clutch

**The relation of indication on torque adjusting ring and torque of clutch disengaging**

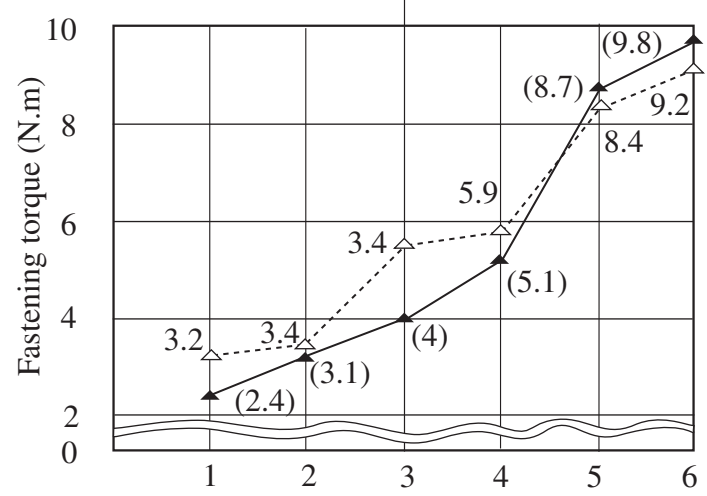

▲————▲ 6827  
△-----△ 6805BV

<Note>  
The torque of clutch disengaging may differ depending on the pressure load.

**Indication on torque adjusting ring and capacity**

Screws and its size	Indication on torque adjusting ring
Machine screw M5 - M8	1 - 3
Wood screw 3.5	1
Wood screw 4.1	1
Wood screw 4.5	1
Wood screw 5.1	2 - 3
Wood screw 5.8	3 - 4
Wood screw 6.2	4 - 5
Self drilling screw 5 .6mm	6 In case of self drilling screws, the clutch does not disengage. So, the stopper has to be used.

\* The above listed figures may differ depending on the working conditions, such as quality of screws, materials to be fastened, pressure load, etc.

Model No.	Makita		De WALT	
	6827	6805BV	DW268	
Power Input (W)	570	510	—	
Continuous rating current (A) on 120V	6.5	4.8	6.5	
No load speed : min-1=rpm	0 - 2,500			
Max. screwdriving capacity	Self drilling screw : 6mm (#14) Hex screw : 6mm (#14) Wood screw : 6.2mm (1/4") Machine screw : M8 (5/16")		Self drilling screw : 6mm (#14)	
Fastening torque control	Yes (6 stages)		Yes (10 stages)	
Fastening depth adjustment	Yes		No	
Belt clip	Yes (Retractable)	Yes	Yes	
Soft-grip handle	Yes	No	Yes	
Double insulation	Yes			
Center height : mm (")	23.3 (15/16)	29.5 (1-3/16)	25.6 (1)	
Dimensions : mm (")	Length	304 (12)	279 (11)	302 (11-7/8)
	Width	70 (2-3/4)	73 (2-7/8)	65 (2-9/16)
	Height	218 (8-5/8)	199 (7-7/8)	176 (6-15/16)
Net Weight : Kg (lbs)	1.8 (4.0)	1.9 (4.2)	1.5 (3.2)	
Standard equipments	Plastic case	Steel case		

**Comparison of fastening speed per screw**

Numbers in chart below are relative values when setting 6805BV 's capacity as 100.

Testing conditions

- \* Testing voltage : 120 V
- \* The connected extension cord : 1.25mm<sup>2</sup> x 60m
- \* Pressure load : 150 N / 200 N

Model		Pressure load : 150 N	Pressure load : 200 N	Testing materials	
				Screws	Materials to be fastened
MAKITA	6827	100	110	Hex screw Ø6 x 25mm	Spruce: 2mm thick + Steel : 3.2mm thick
	6805BV	100	100		
DeWALT	DW268	90	110		
MAKITA	6827	95	105	Hex screw Ø4 x 25mm	Steel : 3.2mm thick
	6805BV	100	100		
DeWALT	DW268	85	100		
MAKITA	6827	140	120	Teks screw Ø6 x 16mm	Steel : 3.2mm thick
	6805BV	100	100		
DeWALT	DW268	110	90		
MAKITA	6827	110	110	Teks screw Ø6 x 70mm	Spruce: 3.2mm thick + Lauan
	6805BV	100	100		
DeWALT	DW268	95	100		

## < 1 > Lubrication

Apply MAKITA Grease N No.1 to the parts illustrated in Fig. 1.

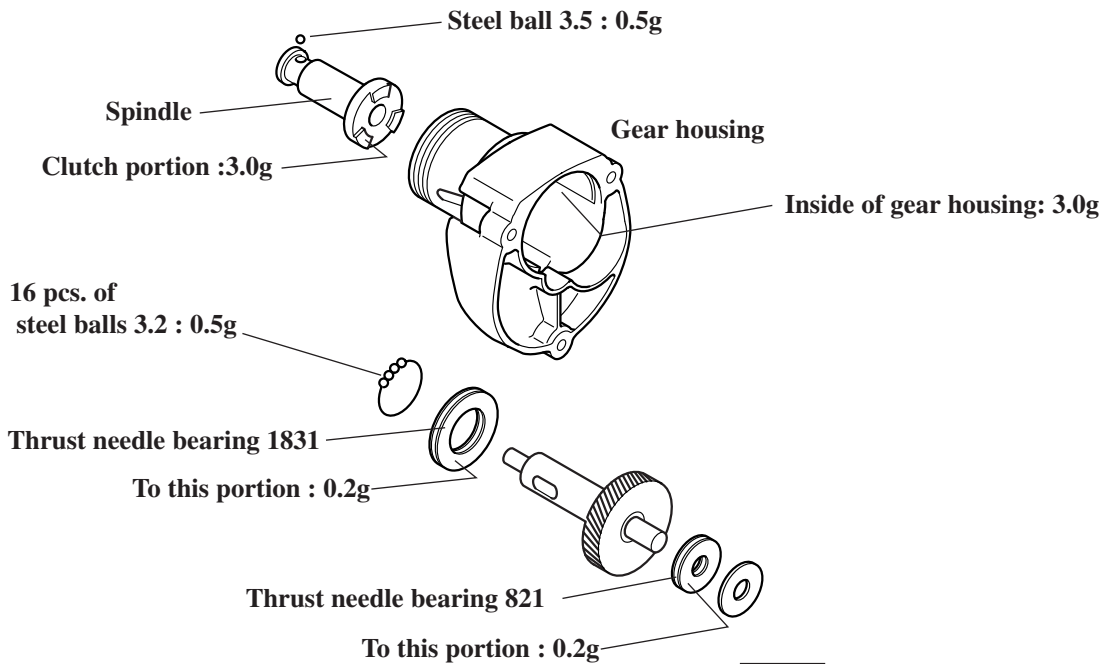

Fig. 1

## < 2 > Disassembling

### (1) Disassembling clutch cover

Disassemble clutch cover by turning it clockwise as illustrated in Fig. 2.

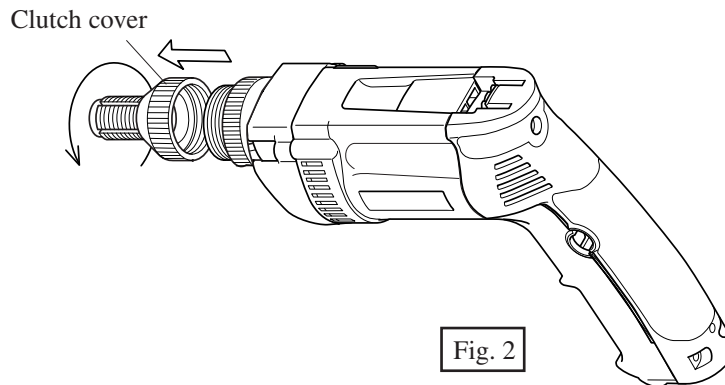

Fig. 2

### (2) Disassembling ring 36

Disassemble ring 36 by turning it anti-clockwise as illustrated in Fig. 3.

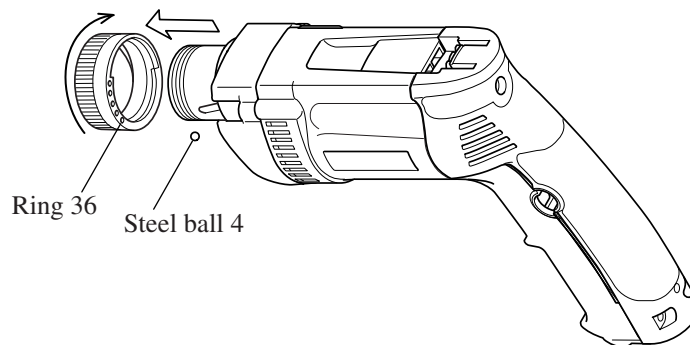

Fig. 3

< Note > Pay attention, not to lose steel ball 4 in this process.

(3) Disassembling ball bearing 606

Disassemble ball bearing 606 by striking gear housing with plastic hammer as illustrated in Fig. 4.

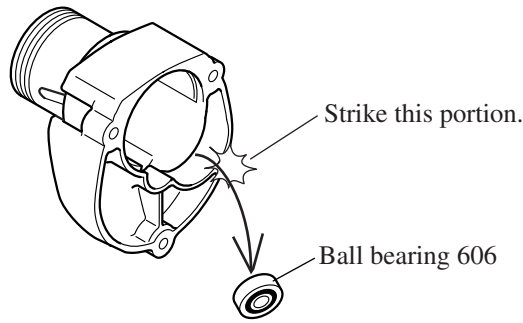

Fig. 4

(4) Disassembling torque adjusting section

Take off torque adjusting section after removing 2 pcs. of pins 4 and gear complete 17-35 as illustrated in Fig. 5 and Fig. 5A..

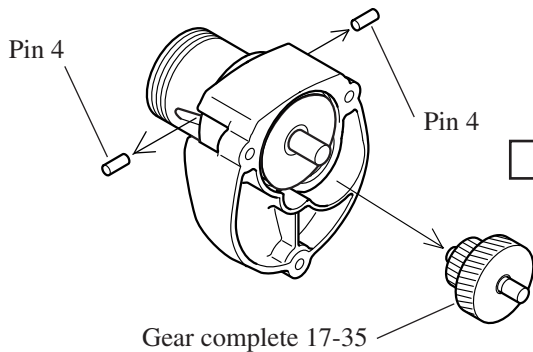

Fig. 5

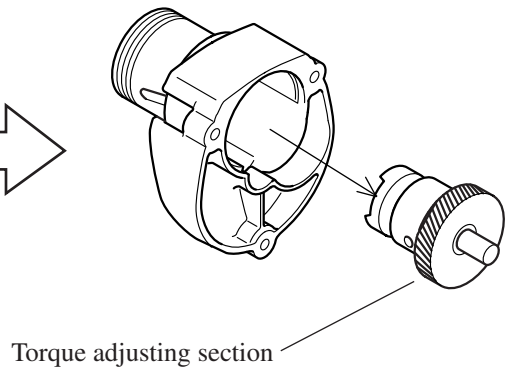

Fig. 5A

Turn the handle of large gear extractor clockwise, so clutch cam is pressed to gear portion, and then 3 pcs. of steel balls 5.6 which is fixing clutch cam on gear complete, can be taken off from gear complete.

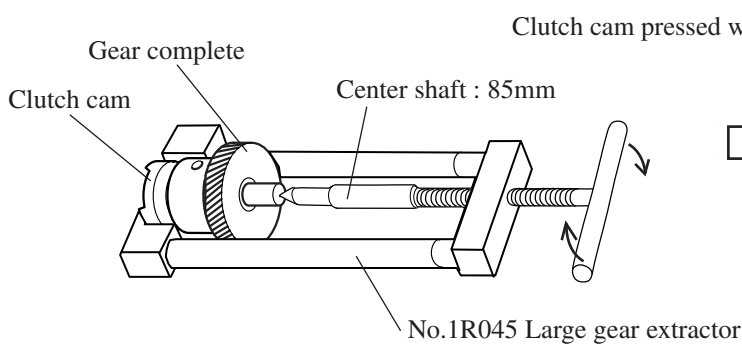

Fig. 6

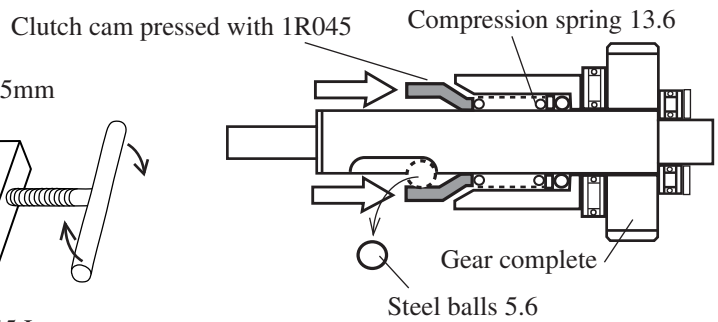

Fig. 6A

After removing 3 pcs. of steel ball 5.6, the torque adjusting section can be disassembled as illustrated in Fig. 6B.

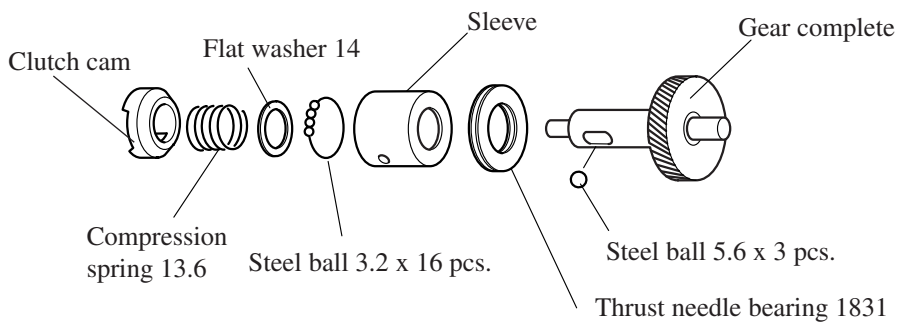

Fig. 6B

< 3 > Assembling

(1) Assembling torque adjusting section See Fig. 7.

Assemble the following parts to gear complete.

- \* Thrust needle bearing 1831
- \* Sleeve

Place flat washer 14 on the 16 pcs. of steel balls 3.2 which have been put on the bottom of sleeve. And then, place compression spring 13.6 and clutch cam on the flat washer 14.

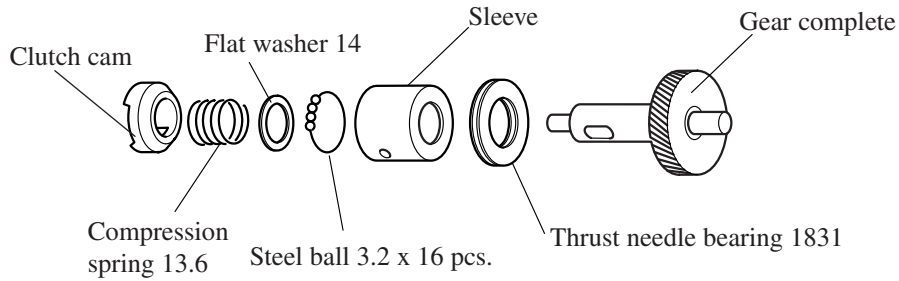

Fig. 7

Place 3 pcs. of steel ball 5.6 into the groove of gear complete by pressing clutch cam with No.1R045 to the gear side as illustrated in Fig. 7A.

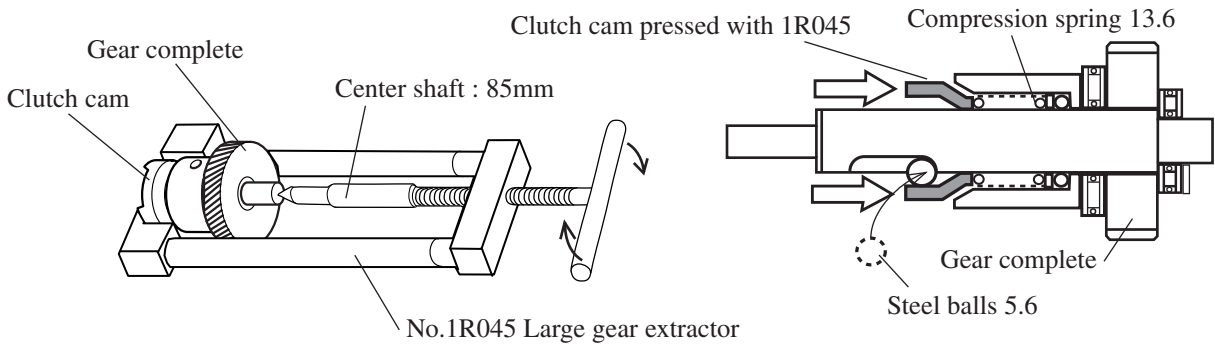

Fig. 7A

(2) Assembling torque adjusting section to gear housing

Assemble torque adjusting section to gear housing with aligning sleeve's hole with elliptic hole of gear housing. And then, assemble 2 pcs. of pins 4 to the elliptic hole of gear housing which has been aligned with sleeve's hole.

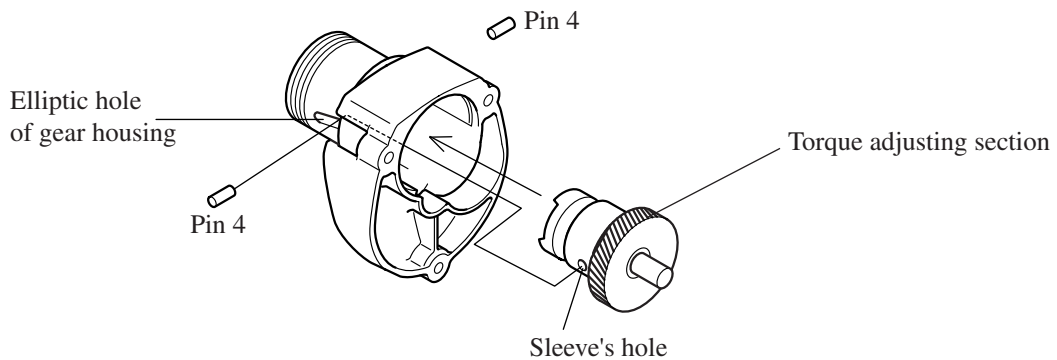
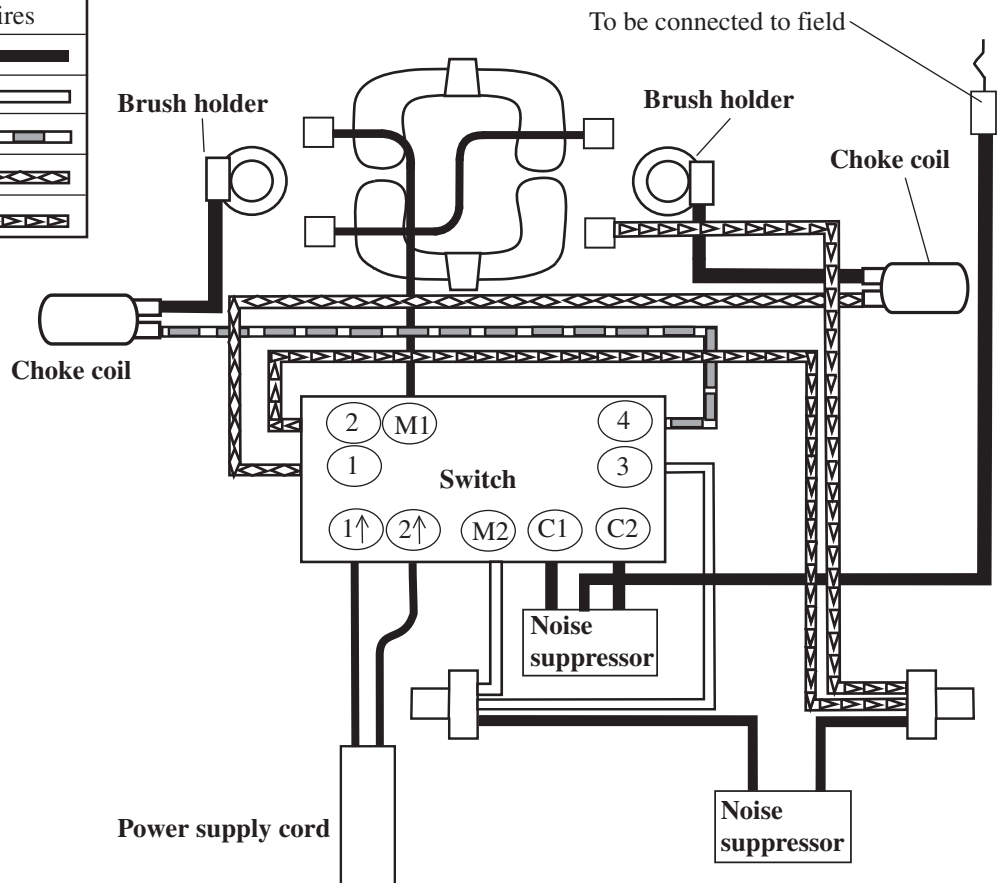

Fig. 8



▶ **Circuit diagram (for the market where noise suppressor is required.)**





Color index of lead wires	
Black	
White	
Red	
Blue	
Brown	

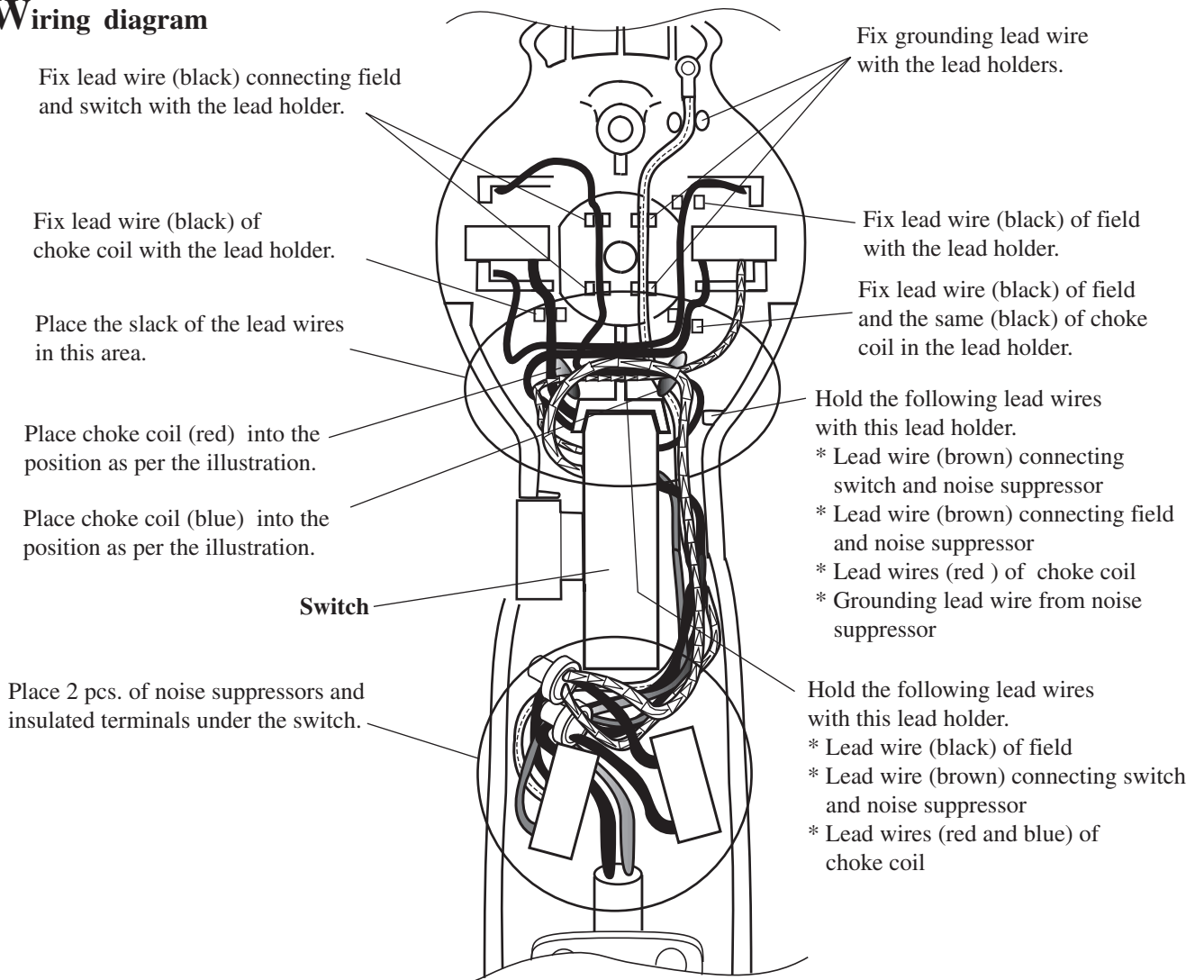

▶ **Wiring diagram**



▶ **Circuit diagram**

Color index of lead wires	
Black	
White	
Red	
Blue	

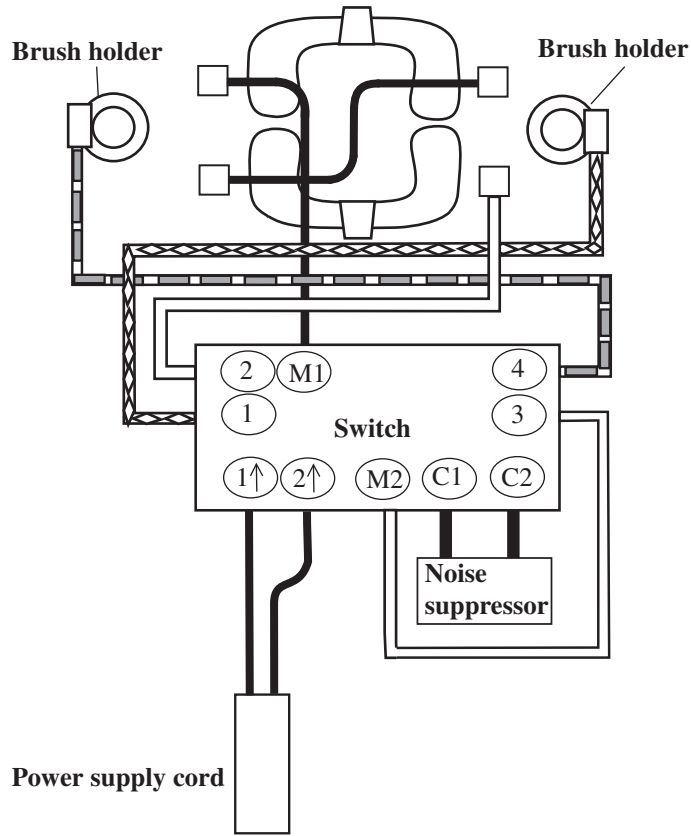

▶ **Wiring diagram**

