

Models No. ▶ 6830

Description ▶ Auto Feed Screwdriver

CONCEPTION AND MAIN APPLICATIONS

Model 6830 is a screwdriver with a mechanism to feedscrews automatically. So you do not need to do bothersome-by-one setting driving. Shorter tool length, well-balanced design and in-line D-handle assures easier operation.

(Note)

This tool is not offered to some countries and areas. Consult Makita Japan on this matter.

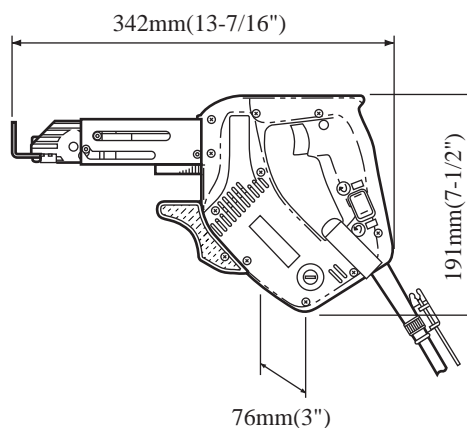

▶ Specifications

Voltage (V)	Current (A)	Cycle (Hz)	Continuous Rating (W)		Max. Output(W)
			Input	Output	
100	5.0	50/60	470	220	400
115	4.3	50/60	470	220	400
200	2.5	50/60	470	220	400
220	2.3	50/60	470	220	400
230	2.2	50/60	470	220	400
240	2.1	50/60	470	220	400

Capacities

Drywall Screw	4mm x 25mm (5/32"x 1")
	4mm x 28mm (5/32"x 1-1/8")
	4mm x 32mm (5/32"x 1-1/4")
	4mm x 40mm (5/32"x 1-9/16")
No Load Speed	0 - 4,700 R/min.
Net Weight	1.9Kg (4.2 lbs.)

▶ Standard equipment

Phillips Bit 2-117 (3 pcs.), Hex Wrench 3, Plastic Carrying Case

▶ Optional accessories

Phillips Bit 2-117 (5 pcs. per pkg)

▶ Features and benefits

1. Double insulated
2. Refer to the attached sheet for more information.

