

TECHNICAL INFORMATION

Makita

New Tool

Models No. ▶ 6832

Description ▶ Auto Feed Screwdriver

CONCEPTION AND MAIN APPLICATIONS

This tool accepts screw strips $\phi 4\text{mm}$ (5/32") x25mm(1") to 57mm(2-1/4"). Use of extension handle (optional accessories) allows you to drive screws into floor while standing.

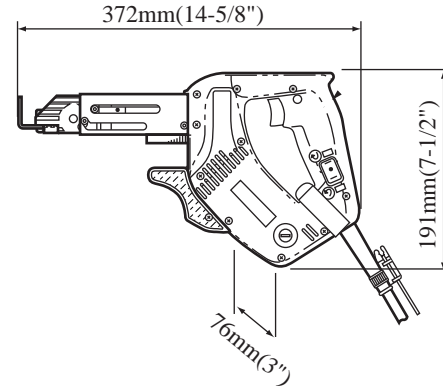

▶ Specifications

| Voltage (V) | Current (A) | Cycle (Hz) | Continuous Rating (W) | | Max. Output(W) |
|-------------|-------------|------------|-----------------------|--------|----------------|
| | | | Input | Output | |
| 100 | 5.0 | 50/60 | 470 | 220 | 400 |
| 115 | 4.3 | 50/60 | 470 | 220 | 400 |
| 200 | 2.5 | 50/60 | 470 | 220 | 400 |
| 220 | 2.3 | 50/60 | 470 | 220 | 400 |
| 230 | 2.2 | 50/60 | 470 | 220 | 400 |
| 240 | 2.1 | 50/60 | 470 | 220 | 400 |

Capacities

| | |
|---------------|--|
| Screw strip | $\phi 4\text{mm}$ (5/32")x25mm (1")-57mm(2-1/4") |
| No Load Speed | 0-2,800 R/min. |
| Net Weight | 2.0Kg (4.4 lbs) |

▶ Standard equipment

Hex wrench, Wrench holder, Phillips bit 2-132 (2 pcs.), Stopper plate for screws 25 mm (1") to 41 mm (1-5/8") long, Hex socket head bolt M4x8, Plastic carrying case

▶ Optional accessories

Phillips bit 2-132 (5 pcs. in set), Extension handle

▶ Features and benefits

See information sheet which we will send you later.

This is additional information on Model 6832 (Auto Feed Screwdriver).
Attach this information sheet to MAKITA NEW TOOL INTRODUCTION NT-1/95.

