

T ECHNICAL INFORMATION

Models No. ▶ 6953

Description ▶ Impact Wrench

CONCEPT AND MAIN APPLICATIONS

The above model is the impact wrench with max. fastening torque, 150N.m.

This model's brief features and benefits are

- * palm fitting soft grip
- * Removable belt clip can be attached on both left and right side without any tool.

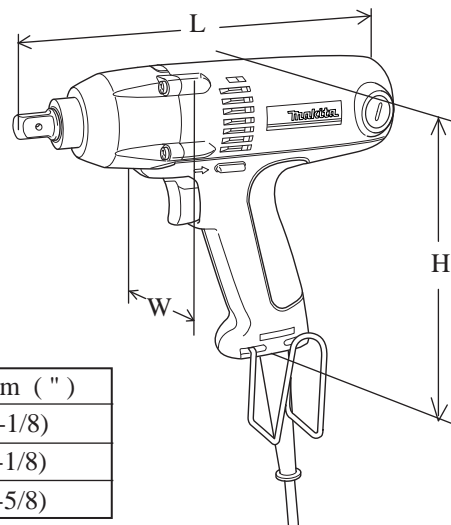

Dimensions : mm (")	
Length (L)	233 (9-1/8)
Height (H)	180 (7-1/8)
Width (W)	67 (2-5/8)

► Specification

Voltage (V)	Current (A)	Cycle (Hz)	Continuous Rating (W)		Max. Output(W)
			Input	Output	
110	2.7	50 / 60	280	120	240
120	2.5	50 / 60	280	120	240
220	1.3	50 / 60	280	120	240
230	1.3	50 / 60	280	120	240
240	1.2	50 / 60	280	120	240

No load speed (min.₁=rpm)	0 - 3,000	
Impact per minute (min.₁=bpm)	0 - 3,000	
Driving shank : mm (")	12.7 (1/2)	
Capacities	Standard bolt	M10 - M16
	High Tensile bolt	M8 - M12
Max. fastening torque	150 N.m (110 ft.lb)	
Variable switch	Yes	
Reverse switch	Yes	
Protection from electric shock	by Double insulation	
Cord length : m (ft)	2.5 (8.2)	
Net weight: kg (lbs)	1.4 (3.1)	

► Standard equipment

- * Plastic carrying case 1 pc.

< Note > The standard equipment for the tool shown may differ from country to country.

► Optional accessories

- * Socket 17-38
- * Socket 17-52
- * Socket 19-38
- * Socket 19-52
- * Socket 21-38
- * Socket 21-52
- * Socket 22-38
- * Socket 22-52
- * Socket 23-38
- * Socket 23-52
- * Socket 24-45
- * Socket 24-52
- * Socket 26-50
- * Socket 26-78
- * Socket 21-78
- * Socket 19-78
- * Universal joint
- * Extension bar
- * Bit adapter
- * Oval socket assembly

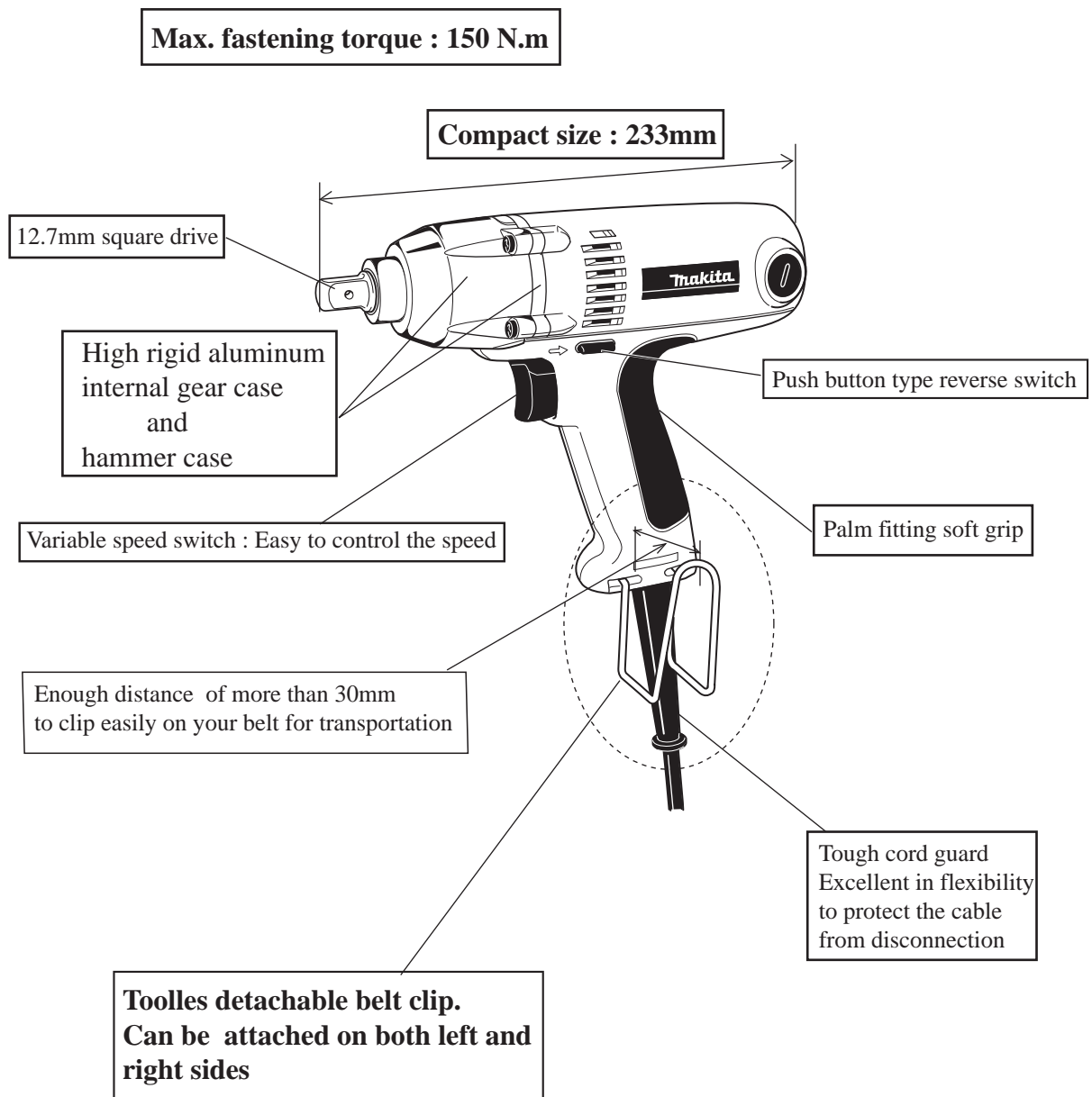

< 1 > Disassembling housing set

- 1) Take off 4 pcs. of hex socket head bolts M4x30. And then, remove hammer case and internal gear case from housing. See Fig. 1.
- 2) Take off 7 pcs. of tapping screws 4 x 18. So, housing can be removed. See Fig. 1.

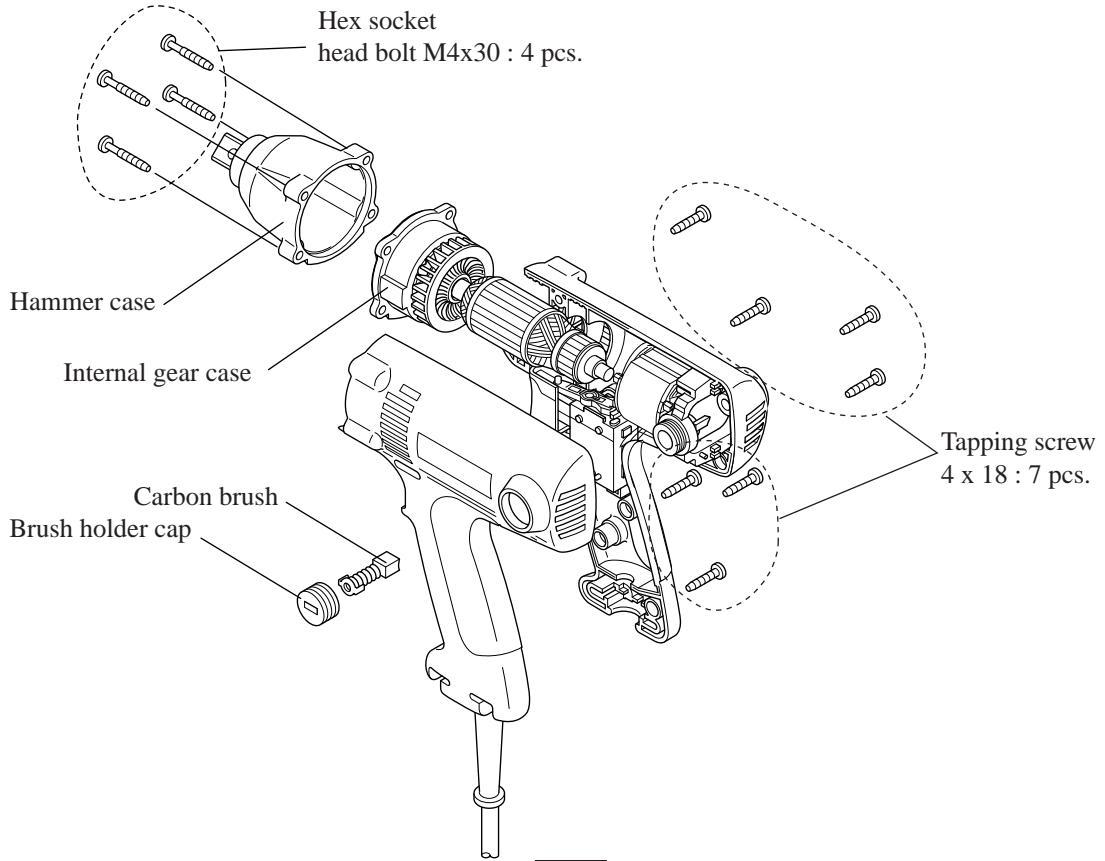
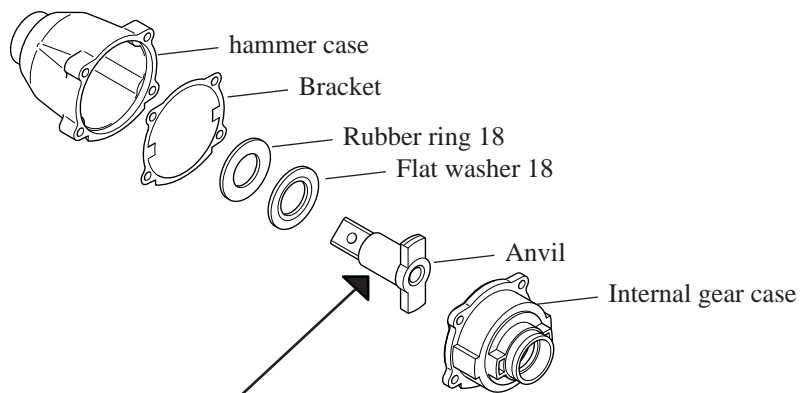

Fig. 1

< 2 > Assembling anvil

Assemble rubber ring 18 and flat washer 18 into hammer case. And then, assemble anvil on which grease has been applied in advance. See Fig. 2.

<Note> Make sure that bracket has been assembled between hammer case and internal gear case.



Apply 0.1 g of MAKITA grease N No.1 to the cylindrical portion of anvil marked with black triangle, to protect parts and machine from unusual abrasion.

Fig. 2

< 3 > Disassembling hammer

(1) Press down hammer with 1R045: Large gear extractor by turning the handle.

(2) Adjust the opening for steel ball inserting to the cam groove top of spindle.

(3) Take off 2 pcs. of steel balls 5.6 from spindle.

< Note > 25 steel balls 3.5 are installed in hammer.
Check the quantity when assembling.

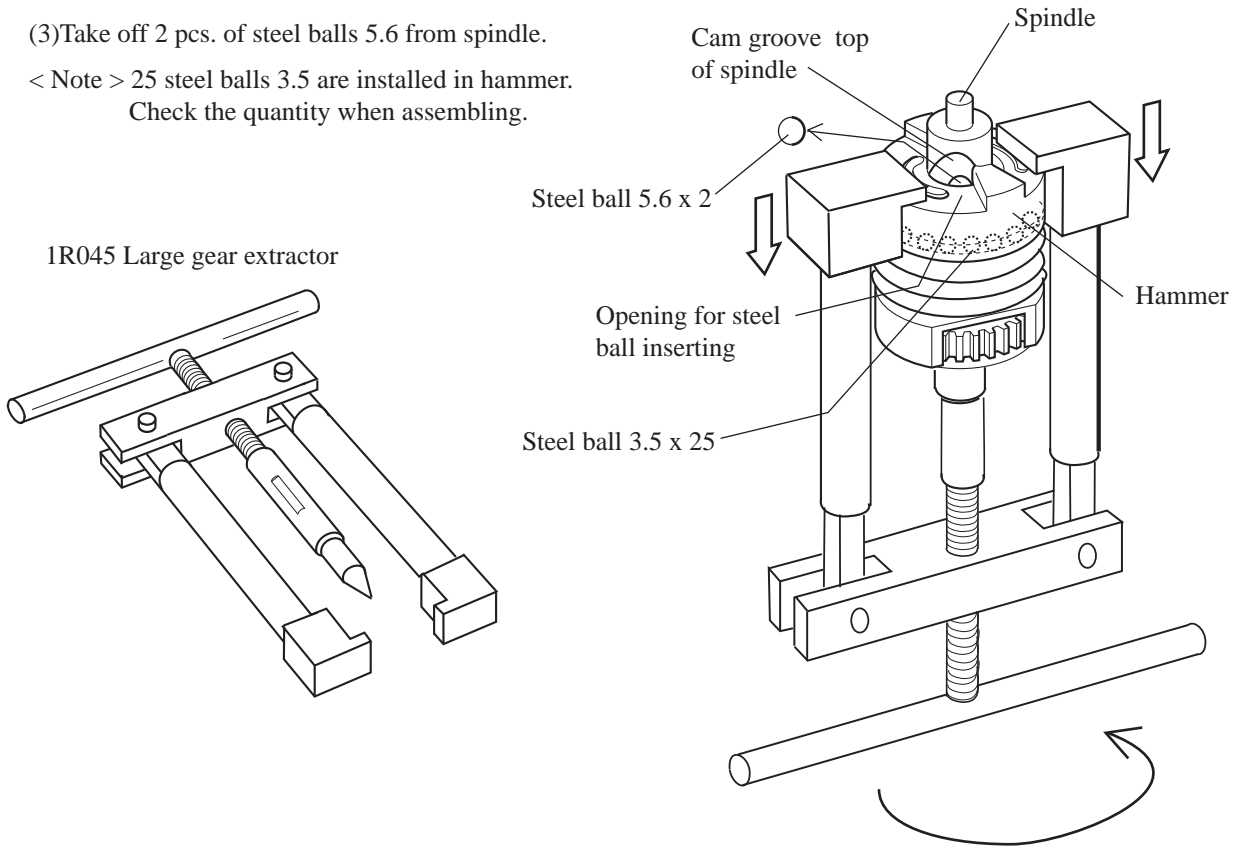

Fig. 3

(4) Apply grease to the position No. 1, 2, 3 and 4 as listed below, when assembling.

	MAKITA grease N No.1	Molybdenum di-sulphide lubricant
(1)	0.5g	0.2g
(2)	0.5g	—
(3)	—	0.6g
(4)	1.0g	0.2g

(3) to Steel ball 5.6 x 2

(2) to Steel ball 3.5 x 25

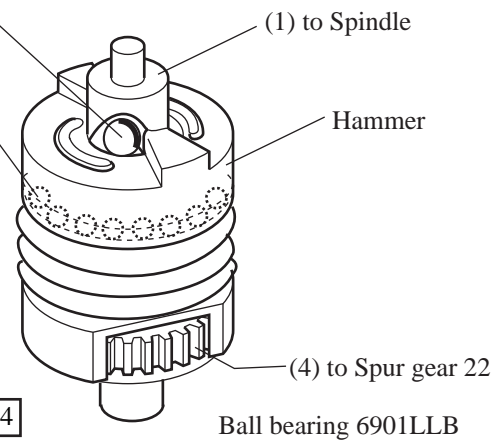

Fig. 4

Ball bearing 6901LLB

< 4 > Assembling housing R and L

When assembling housing R to housing L, make sure that 2 pcs. of rubber pins 4 have been attached to the illustrated portion of housing R. See Fig. 5.

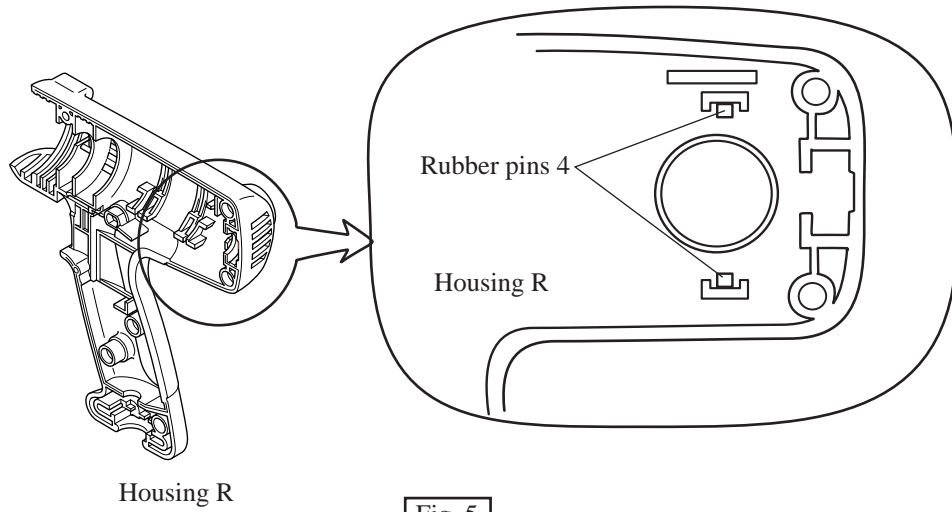

Fig. 5

< 5 > Hammer case has to be fastened diagonally as illustrated in in Fig.6.

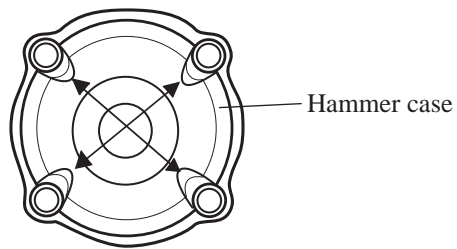
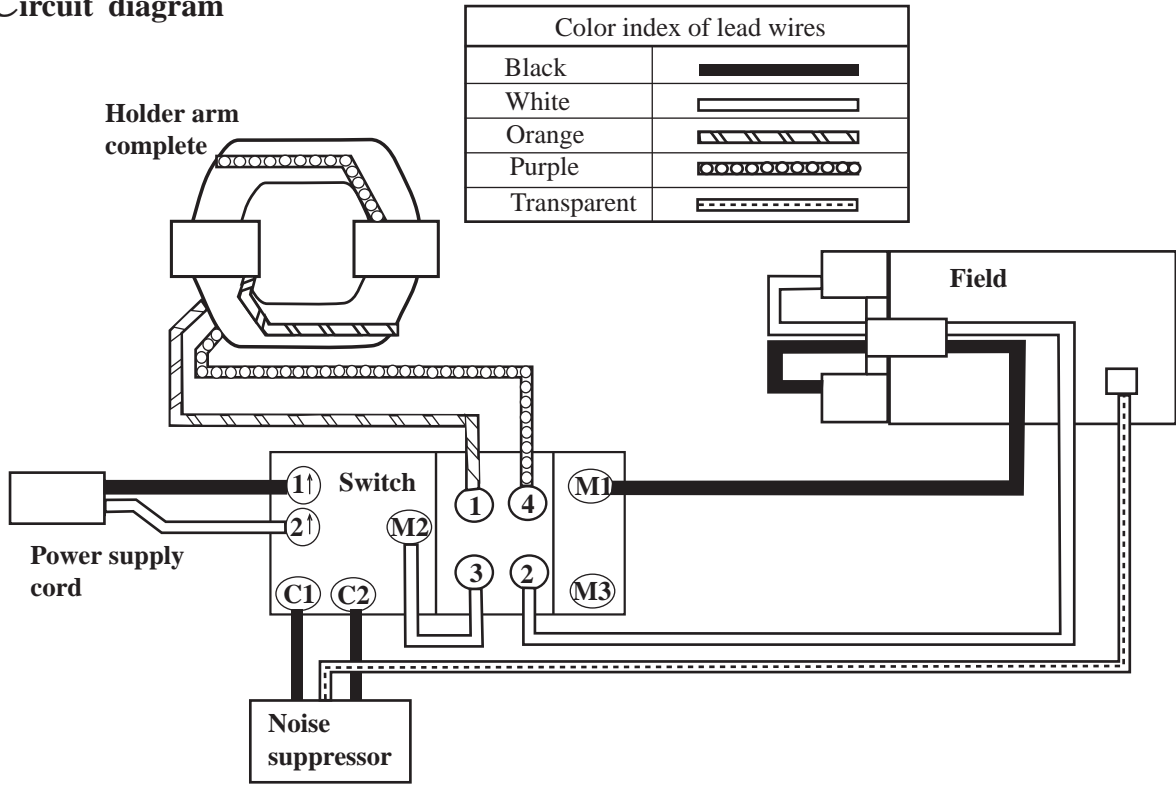

Fig.6

► **Circuit diagram**



The products may come with noise suppressor of 2 lead wire type, or without noise suppressor for some countries.

► **Wiring diagram**

