

TECHNICAL INFORMATION



NEW TOOL

P 1 / 5

Models No. ▶ 9015A

Description ▶ 125mm (5") Angle grinder

CONCEPTION AND MAIN APPLICATIONS

Now model 9015A has been released for North American market (low voltage area), as a sister model of Mod.9015DB. Its brief benefits and features are as follows.

- * equipped with Electric Brake for quick stop and speedy work.
- * equipped with Super Joint System which features suppression of starting shock, and protection of machine itself and users from accidental spindle lock
- * equipped with large switch trigger for easy and comfortable switch operation

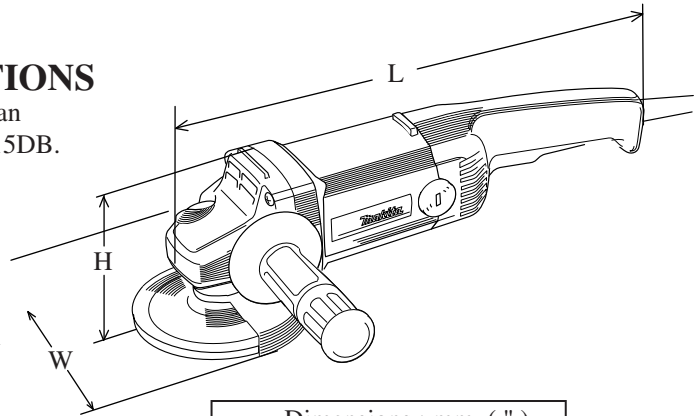

Dimensions : mm (")	
Width (W)	139 (5-1/2)
Height (H)	120 (4-3/4)
Length (L)	384 (15-1/8)

► Specification

Voltage (V)	Current (A)	Cycle (Hz)	Continuous Rating (W)		Max. Output(W)
			Input	Output	
120	10	AC / DC	1,140	520 / 680	1,600 / 2,000

No load speed : (min -i= rpm)	10,000	
Wheel size : mm (")	Diameter	125 (5)
	Thickness	6 (1/4)
	Hole diameter	22.23 (7/8)
Electric brake	Yes	
Super joint system	Yes	
Protection from electric shock	by double insulation	
Net weight :Kg (lbs)	2.5 (5.5)	
Cord length : m (ft)	2.5 (8.2)	

► Standard equipment

- * Depressed center wheel 125 (WA36N) 1 pc.
- * Lock nut wrench 1 pc.

< Note > The standard equipment for the tool shown may differ from country to country.

► Optional accessories

- * Depressed center wheel 125 (WA36N)
- * Rubber pad 115
- * Abrasive disc 125 - 24, 30, 50, 80, 120
- * Wire cup brush 90mm
- * Wheel cover for wire cup brush 90mm
- * Lock nut for abrasive disc
- * Cut off wheel 125mm - No.10
- * Dust collecting wheel cover

► **Features and benefits**

"Super Joint System - SJS"

Lock spring joining spiral bevel gear and armature shaft provides following benefits.

- * Smooth and comfortable grinding work.
- * Suppression of shock by accidental wheel lock during work.
- * Prevention of damage on gear coming from accidental wheel lock.

Tough motor against grinding dust

thanks to armature coated with varnish, and field protected with tape

Electric brake

Only 1/2 time from switch off to wheel's stop as compared with the existing angle grinders.
And suppressed shock, when braking

Large shaft lock button

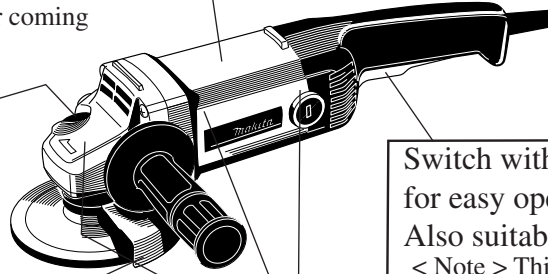

Switch with large trigger for easy operation.
 Also suitable for DC use
 < Note > This switch is not equipped with lock on button.

Adjustable wheel cover's position

Wheel cover's position can be adjusted without any tool.
 < Note > The above wheel cover is an optional accessory.

Dust proof type ball bearings are equipped in the portion illustrated below.

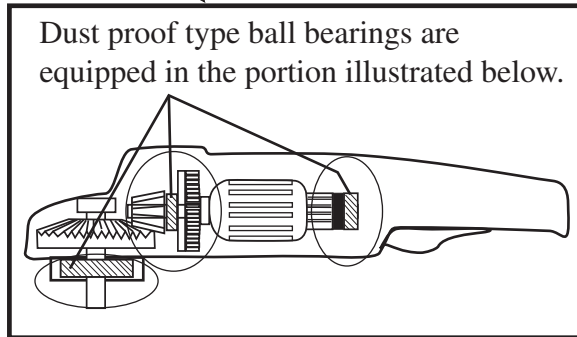

► **Comparison of products**

Model No. Specifications	MAKITA			
	9015A	9015DB	9015B	9005B
Rated current (A) according to UL and CSA	10	12.5	12.5	10 for Canada 9 for U.S.A.
Wheel diameter : mm (")	125 (5)	125 (5)	125 (5)	125 (5)
No load speed : (min -1= rpm)	10,000	10,000	10,000	10,000
Switch	AC/DC with large trigger	AC/DC with large trigger	AC/DC with large trigger	AC/DC with large trigger
Brake	Yes	Yes	Yes	Yes
Clutch	Yes (Super joint system)	No	No	No
Net weight :Kg (lbs)	2.5 (5.5)	2.4 (5.3)	2.4 (5.3)	2.4 (5.3)
Standard equipment	* Depressed center wheel * Side grip * Lock nut wrench	* Depressed center wheel * Side grip * Lock nut wrench	* Depressed center wheel * Side grip * Lock nut wrench	* Depressed center wheel * Side grip * Lock nut wrench

< 1 > Replacement of spiral bevel gears

(1) Replacement of spiral bevel gear 12

Hold armature with your hand firmly, and unscrew hex nut with spanner as illustrated in Fig. 1.

<Note> Do not hold armature with vice in this process.

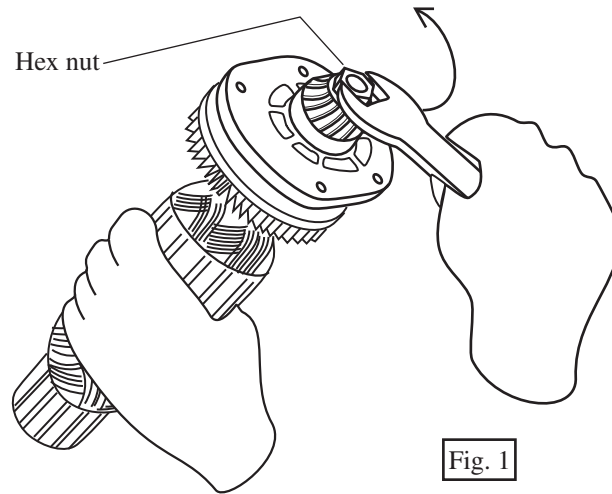

(2) Removing of spiral bevel gear 33, lock spring 17 and lock sleeve

1. Remove retaining ring S-8 with retaining plier, from spindle. Then, flat washer 8, lock washer and spiral bevel gear 33 can be removed from spindle as illustrated in Fig. 2.

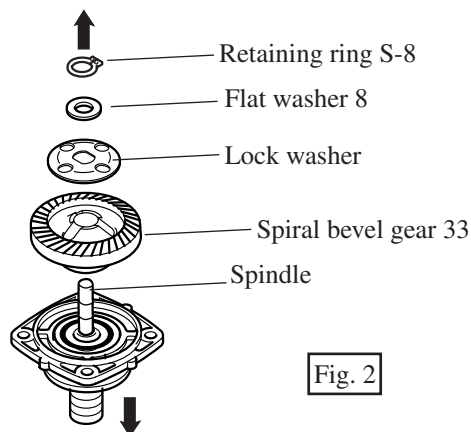

2. Remove lock sleeve from spiral bevel gear 33, with turning it anti-clock wise as illustrated in Fig. 3.

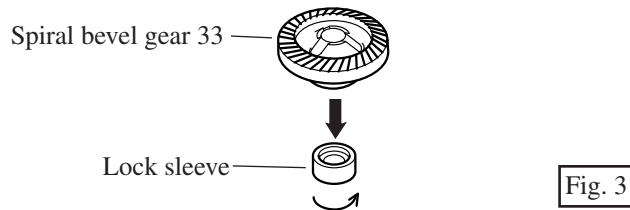

3. Remove lock spring 17 from spiral bevel gear 33, with turning it anti-clock wise as illustrated in Fig. 4.

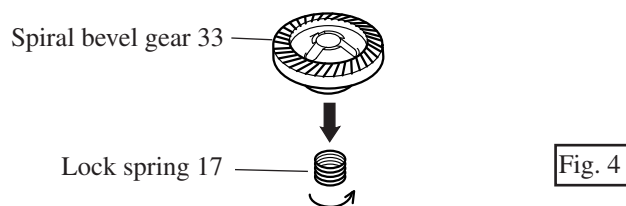

(4) Assembling spiral bevel gear 33, lock spring 17 and lock sleeve

Assemble lock spring 17 to spiral bevel gear 33, with turning it anti-clock wise as same as removing.
See Fig. 5.

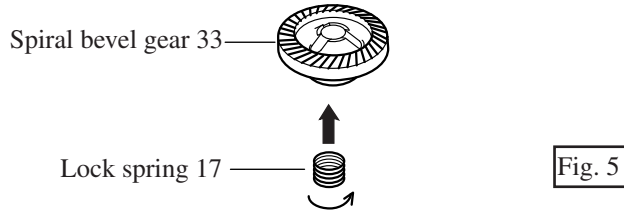

(5) And then, assemble lock sleeve to spiral bevel gear 33, with turning it anti-clock wise as same as removing.
See Fig. 6.

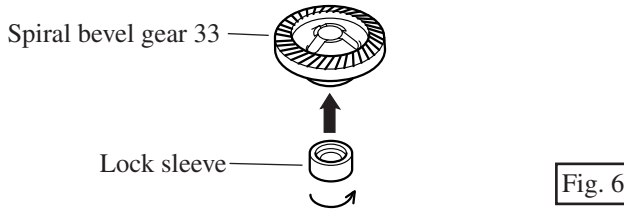

(6) Assemble the spindle section as follows. See Fig. 7.

1. Spiral bevel gear 33 to which lock spring 17 and lock sleeve have been assembled in (5).
2. Lock washer
3. Flat washer 10
4. Retaining ring S -8 with which spiral bevel gear 33, lock washer and flat washer 10 are fixed on spindle.

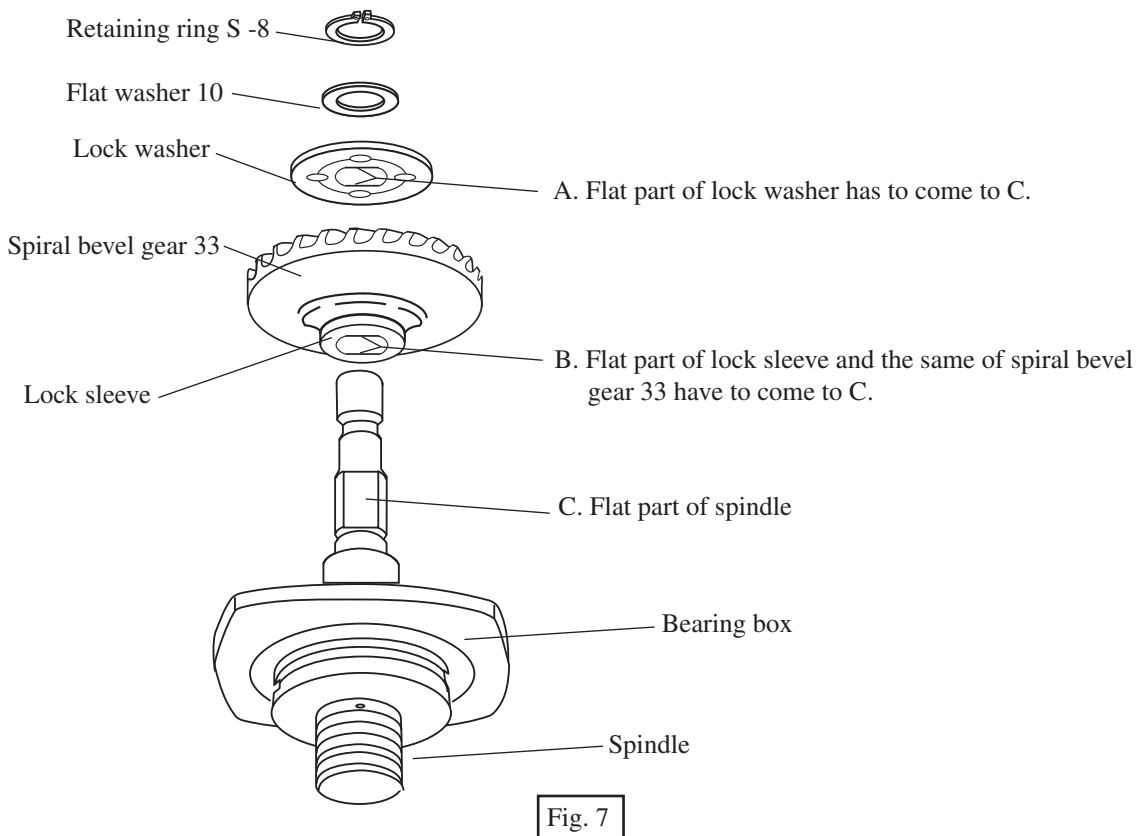

(7) Assembling bearing box

Cut portion of the assembled bearing box has to be faced to the front as illustrated in Fig. 8.

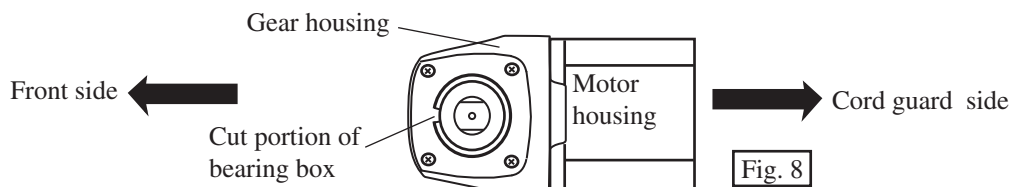

► **Circuit diagram**

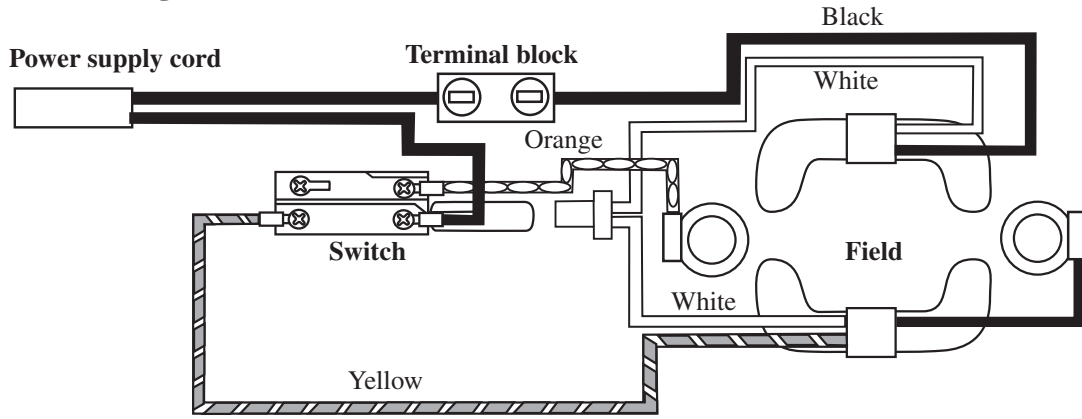

► **Wiring diagram**

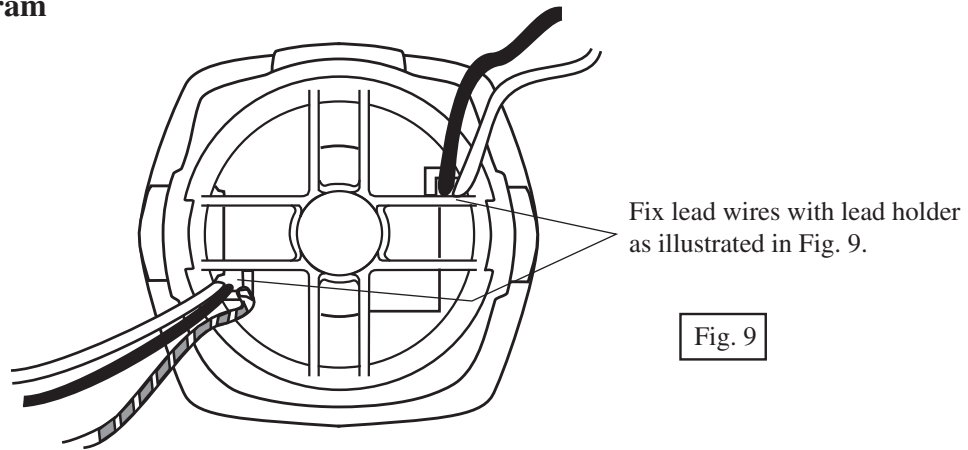

Motor housing
(view from commutator side)

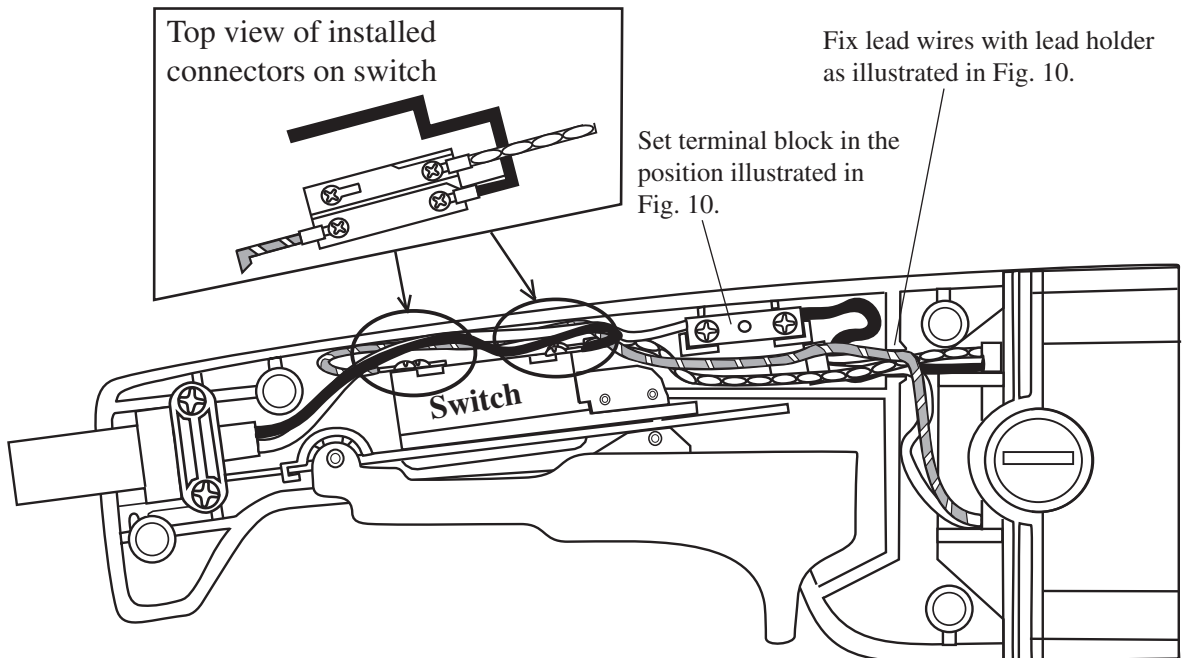

Handle

Fig. 10