

# T ECHNICAL INFORMATION



New Tool

**Models No.** ▶ 9031

**Description** ▶ 30 mm (1-3/16") Belt Sander

## CONCEPTION AND MAIN APPLICATIONS

Model 9031 is an improved version of the existing Model 9030.

- \* More powerful
- \* Equipped with a speed adjusting dial
- \* Can be connected to Makita vacuum cleaner/dust collector

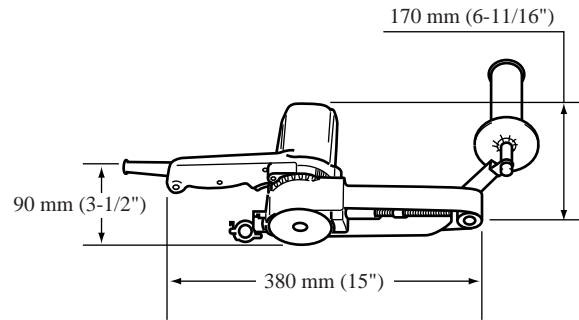

### ► Specifications

| Voltage (V) | Current (A) | Cycle (Hz) | Continuous Rating (W) |        | Max. Output(W) |
|-------------|-------------|------------|-----------------------|--------|----------------|
|             |             |            | Input                 | Output |                |
| 100         | 5.8         | 50/60      | 550                   | 300    | 520            |
| 115         | 5.0         | 50/60      | 550                   | 300    | 520            |
| 220         | 2.6         | 50/60      | 550                   | 300    | 520            |
| 230         | 2.5         | 50/60      | 550                   | 300    | 520            |
| 240         | 2.4         | 50/60      | 550                   | 300    | 520            |

|                   |  |
|-------------------|--|
| <b>Belt size</b>  | 30 mm x 533mm (1-3/16" x 21")                        |
| <b>Belt speed</b> | 200 m/min. 1,000 m/min. (660 ft/mm. - 3,300 ft/min.) |
| <b>Net Weight</b> | 2.1 kg (4.6 lbs)                                     |

### ► Standard equipment

Abrasive belts 533-40, 60, 80, 100, 120 (AA type for wood, iron and steel)

### ► Optional accessories

Abrasive belts 533-40, 60, 80, 100, 120, 150, 240 (AA type for wood, iron and steel), Abrasive belts 533-40, 60, 80, 100, 120, 150 240 (CC type for stone and plastics), Hose 19

### ► Features and benefits

1. Double insulated
2. Refer to the attached sheet for more information.

The standard equipment for the tools shown may differ form country to country

