

T ECHNICAL INFORMATION



Product

Models No. ▶ 9514B, 9514BH

Description ▶ 100 mm / 115 mm Disc grinder

CONCEPTION AND MAIN APPLICATIONS

Switch of both models can be operated with the same hand gripping the machine.

The over load protector protects the motor from over load.

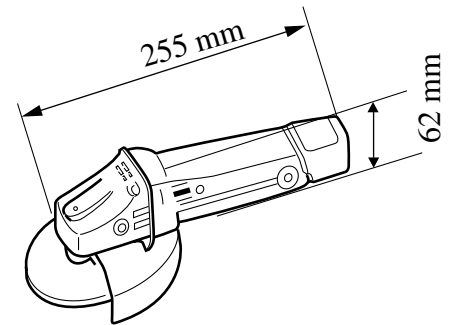

▶ Specifications

Voltage(V)	Current(A)	Frequency(Hz)	Continuous rating		Max. Output (W)
			Input(W)	Output(W)	
100	5.3	50/60	500	270	470
110	4.6				
200	2.7				
220	2.4				
230	2.3				
240	2.2				

	Model No.	9514B	9514BH
Max. Wheel dia. (mm)	Depressed center wheel	100mm (4")	115mm
	Wire cup brush	75mm (3")	75mm (3")
	Wire Bevel Brush	85mm (3-3/8")	85mm (3-3/8")
	Abrasive Disc	100mm (4")	115mm
No load speed		11000/min	
Net weight		1.2 kg	
Cord length		2.5m	

▶ Standard equipment

9514B	9514BH
Depressed Center Wheel 100-36	Depressed Center Wheel 115-36
Lock Nut Wrench 20	Lock Nut Wrench 20
Wrench 14	Wrench 14

The standard equipment for the tools shown may differ from country to country

▶ Optional accessories

9514B	9514BH
Depressed Center Wheel 100-24	Depressed Center Wheel 115-24
Abrasive Disc 100-24, 30, 50, 80, 210	Abrasive Disc 115-24, 30, 50, 80, 210
Rubber Pad 76	Rubber Pad 100
Wire Cup Brush 75	
Wire Bevel Brush 85	
Sanding Lock Nut 30 (for M10x1.25 Spindle Thread)	Sanding Lock Nut 48 (for M14x2, DIN Spindle Thread)
Grip 26	
Grip Holder	