

TECHNICAL INFORMATION



PRODUCT

P 1 / 9

Models No. ▶ 9561, 9564, 9561C, 9561CV, 9564C, 9564CV

Description ▶ Angle grinder 115mm(4-1/2")

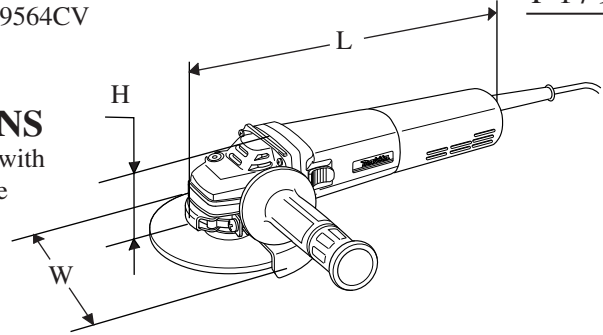

CONCEPTION AND MAIN APPLICATIONS

New series of 115mm (4-1/2") angle grinders are equipped with "Super Joint System-SJS" for protection of user and machine from the shock by accidental spindle lock.

9561C and 9564C are equipped with electronic feature for constant speed, current limiting and soft start, beside "Super Joint System-SJS".

9561CV and 9564CV are equipped with electronic speed control, in addition to the features of 9561C and 9564C.

Dimensions : mm (")		
Model No.	9561, C, CV	9564, C, CV
Width (W)	129 (5-1/16)	129 (5-1/16)
Height (H)	103 (4)	103 (4)
Length (L)	289 (11-3/8)	299 (11-3/4)

► Specification

Model No.	Current (A)					Cycle (Hz)	Continuous Rating (W)		Max. Output(W)
	110V	120V	220V	230V	240V		Input	Output	
9561	—	7.0	3.8	3.7	3.5	50 / 60	800	480	1,000
9564	8.6	7.9	4.3	4.1	3.9	50 / 60	900	540	1,300
9561C/CV	—	9.6	5.3	5.0	4.8	50 / 60	1,100	660	1,600 (120V) 1,800 (220 - 240V)
9564C/CV	—	12.0	6.7	6.4	6.1	50 / 60	1,400	840	2,000 (120V) 2,400 (220 - 240V)

Specifications		Model No.	9561	9561C	9561CV	9564	9564C	9564CV
Wheel size : mm (")	Diameter	115 (4-1/2)						
	Hole diameter	22.23 (7/8)						
	Thickness	6 (1/4)						
No load speed : (min -1= rpm)	North America	10,500		2,800 -10,500		10,500		2,800 -10,500
	Other countries	11,000		2,800 -11,000		11,000		2,800 -11,000
"Super Joint System-SJS"		Yes						
Electronic	Current limiter	No	Yes	Yes	No	Yes	Yes	
	Speed control dial	No	No	Yes	No	No	Yes	
	Soft starter	No	Yes	Yes	No	Yes	Yes	
	Constant speed	No	Yes	Yes	No	Yes	Yes	
Cord length : m (ft)		2.5 (8.2)						
Net weight :Kg (lbs)		1.7 (3.7)			1.8 (4.0)			

► Standard equipment

- * Grip 36 complete 1 pc.
- * Lock nut wrench 20 1 pc.
- * Depressed center wheel 115-36..... 1 pc.

< Note > The standard equipment for the tool shown may differ from country to country.

► Optional accessories

- * Depressed center wheel 115-36
- * Rubber pad 100
- * Lock nut 14-48
- * Dust collection wheel guard
- * Abrasive disc 115-24,30,50,80,120
- * Wire cup brush set 90 mm
- * Wheel cover for wire cup brush 90 mm set
- * Inner flange 47 assembly
- * Diamond wheel 115
- * Head cover

<1> Replacing spiral bevel gear 11

- (1) Remove tapping screw 4x18 and detach rear cover from motor housing.
And remove carbon brush as illustrated in Fig. 1.
- (2) Remove tapping screw 4x28 and detach gear housing from motor housing.
And remove armature with gear housing cover as illustrated in Fig. 1.

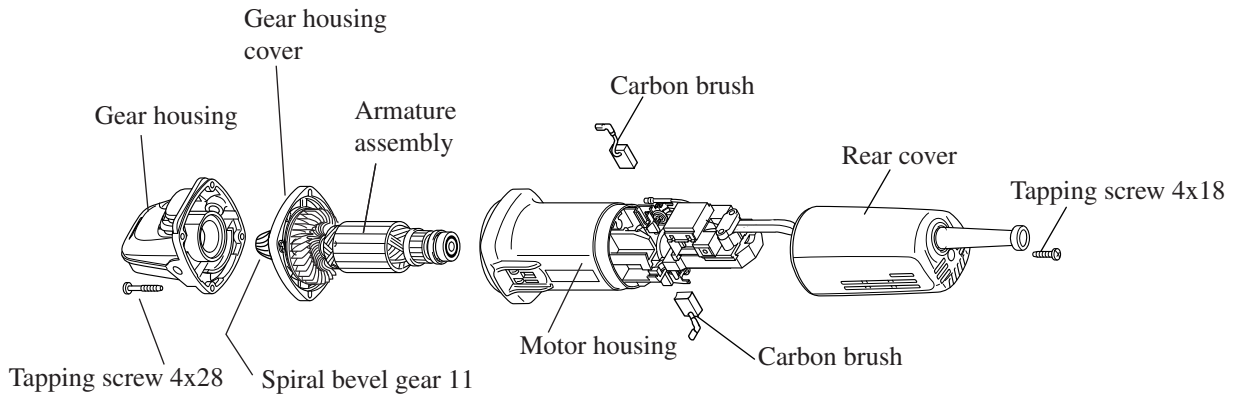

Fig. 1

- (3) Detach hex nut M6 and flat washer 6 from armature as illustrated in Fig.2.

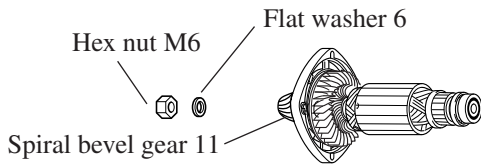

Fig. 2

- (4) Remove spiral bevel gear 11 with bearing extractor No.1R269. And remove lock spring 12 by turning it anti-clockwise. When removing, grip lock spring 12 with gloved hand for anti-skid.

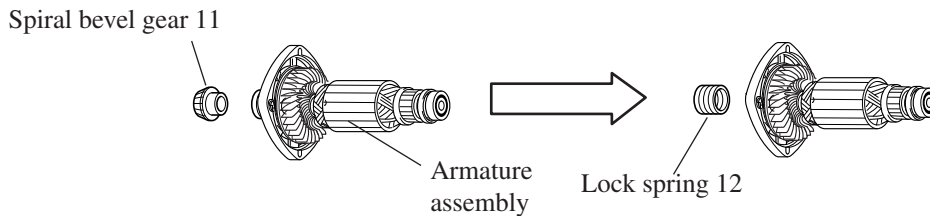

Fig. 3

< Note > Replace lock spring 12 together, when replacing spiral bevel gear 11.

- (5) When assembling spiral bevel gear 11 to armature, take the reverse step.

Attaching carbon brush

Connect the receptacle of carbon brush with the terminal of brush holder by pushing in the direction of the arrow, as illustrated in Fig. 4.

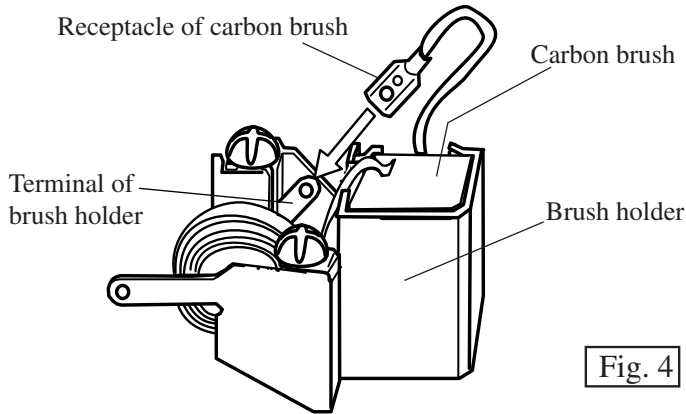

Push the receptacle of carbon brush until it stops as illustrated in Fig. 4A.

Completely attached receptacle of carbon brush

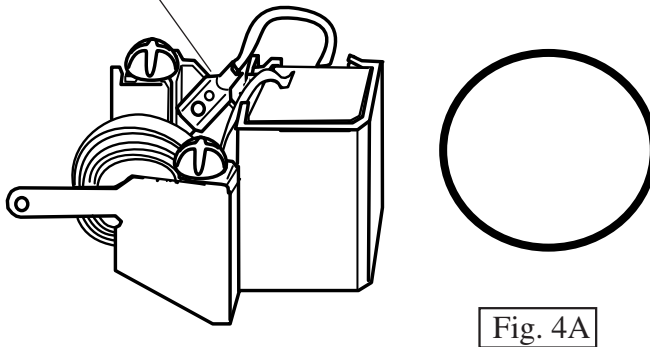

Incompletely attached receptacle of carbon brush

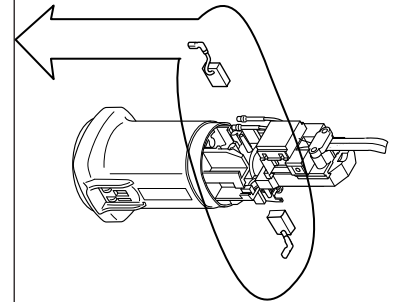
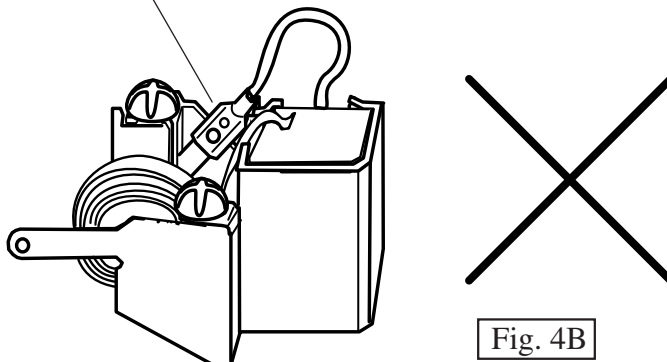

Model 9561C,CV / Model 9564C,CV

with electronic features

Model 9561C and 9564C : without speed control dial

Model 9561CV and 9564CV : with speed control dial

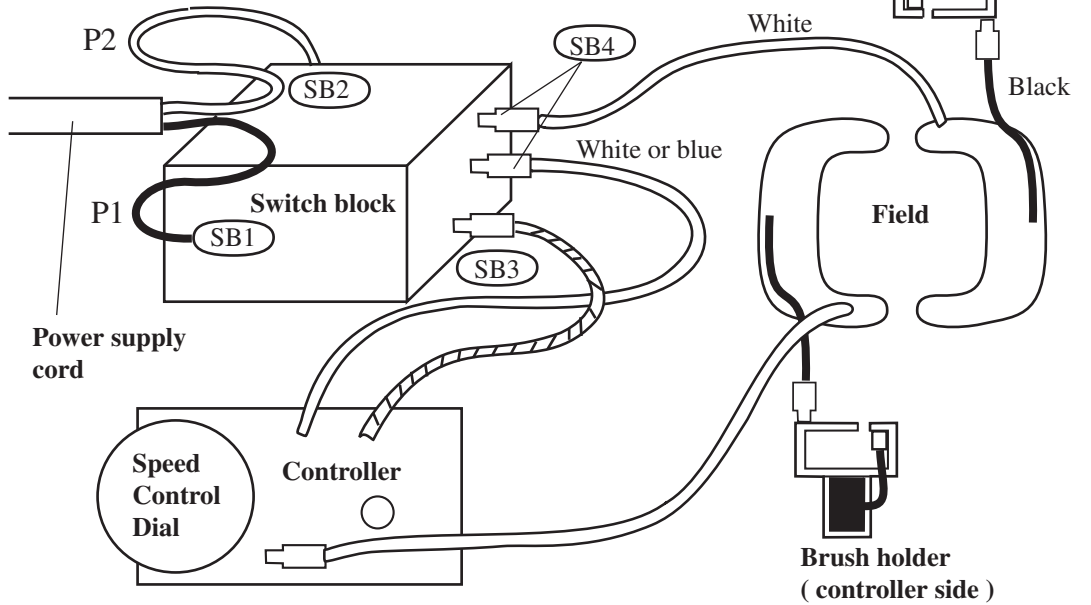

< Note >

The numbers, SB1, SB2, SB3 and SB4 are indicated on the switch block.

Fig. 5

Model 9561 / Model 9564

without electronic features

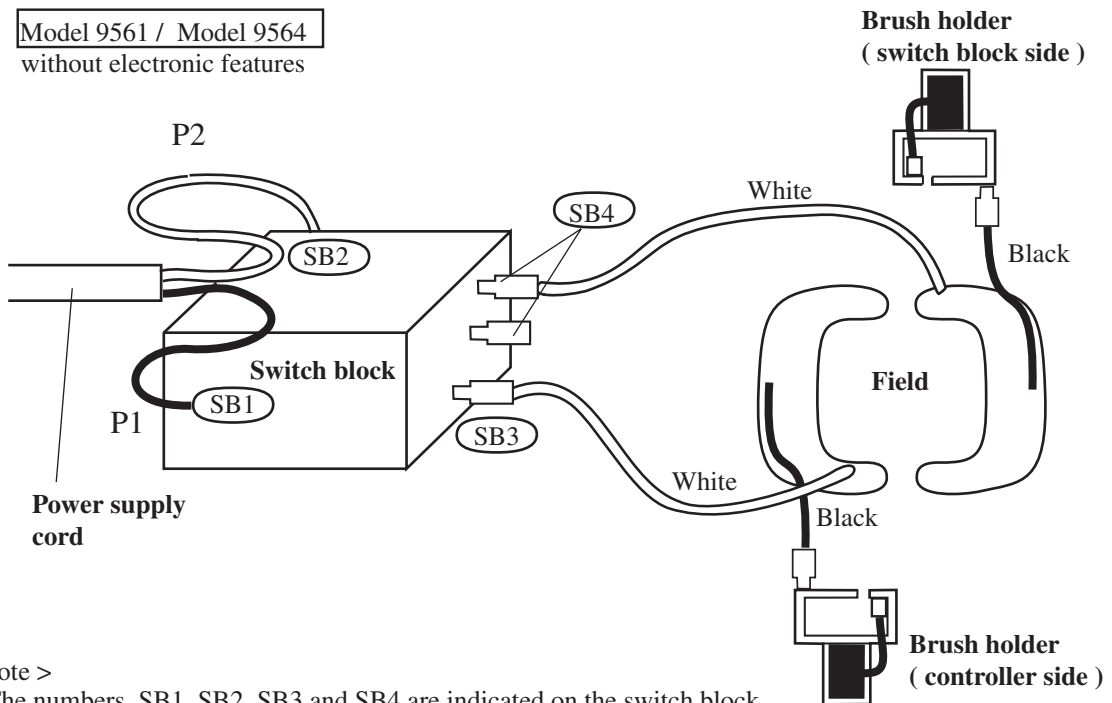

< Note >

The numbers, SB1, SB2, SB3 and SB4 are indicated on the switch block.

Fig. 6

▶ Circuit diagram

Model 9561 / Model 9564

without electronic features
with EMC unit

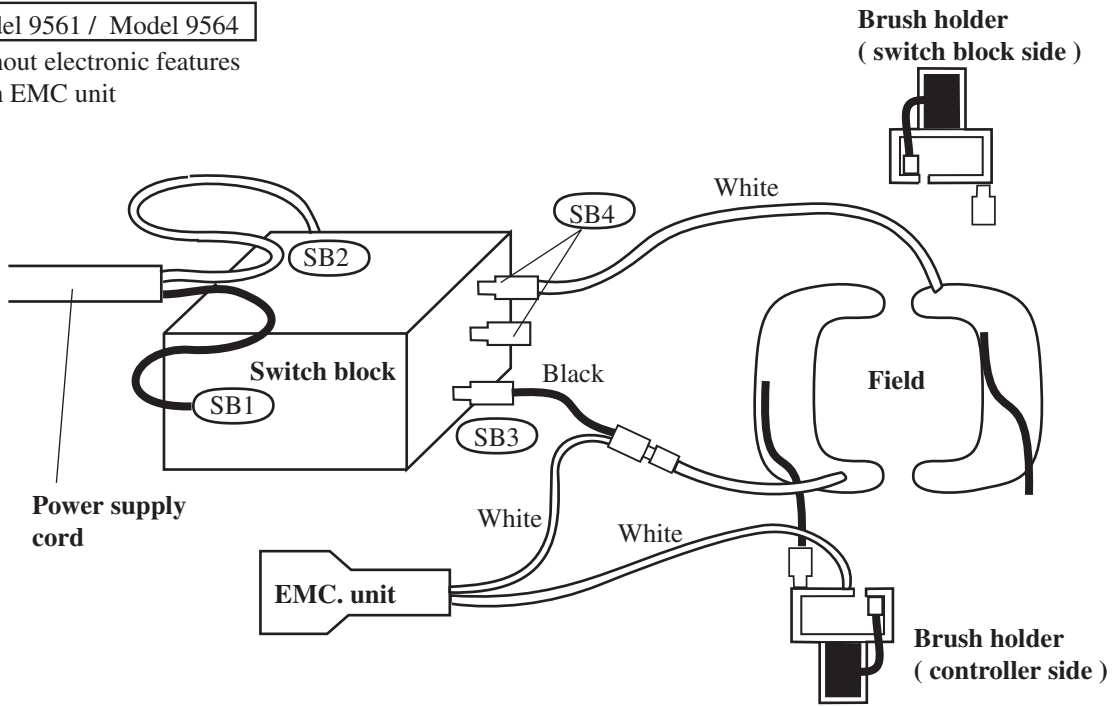

Model 9561C,CV / Model 9564C,CV

with electronic features

Model 9561C and 9564C : without speed control dial

Model 9561CV and 9564CV : with speed control dial

Put the lead wires of controller in the lead holder so that they are not slacken.

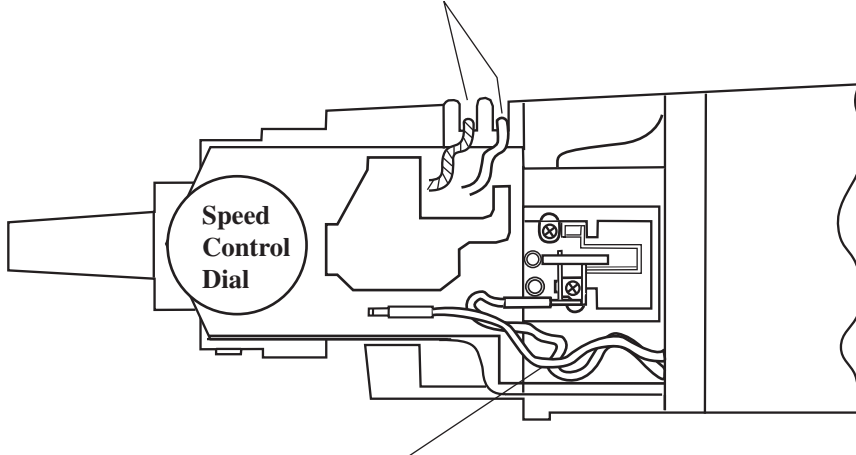

Be careful not to loosen the lead wires of field in motor housing
Put the loosened lead wires in the above place.

Fig. 7

Model 9561C,CV / Model 9564C,CV

with electronic features

Put lead wires of power supply cord by strain relief as illustrated in Fig. 8.

Do not loosen the lead wires of filed in motor housing.
Put the loosened ones in the place as illustrated in Fig.8.

Fix lead wires of controller with lead holder.

Put their slack part in the place as illustrated in Fig.8.

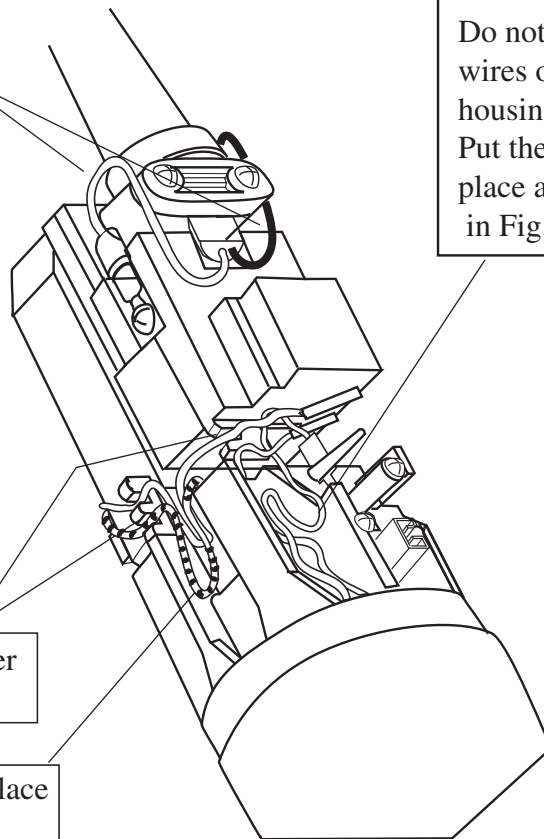

Fig. 8

Model 9561 / Model 9564
without electronic features

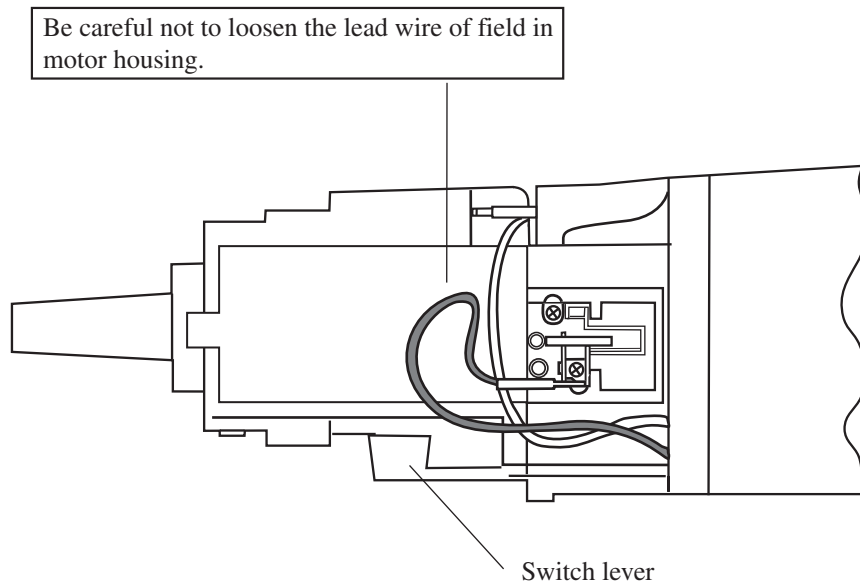

Fig. 9

Model 9561/ Model 9564
without electronic features

Put lead wires of power supply cord by strain relief as illustrated in Fig. 10.

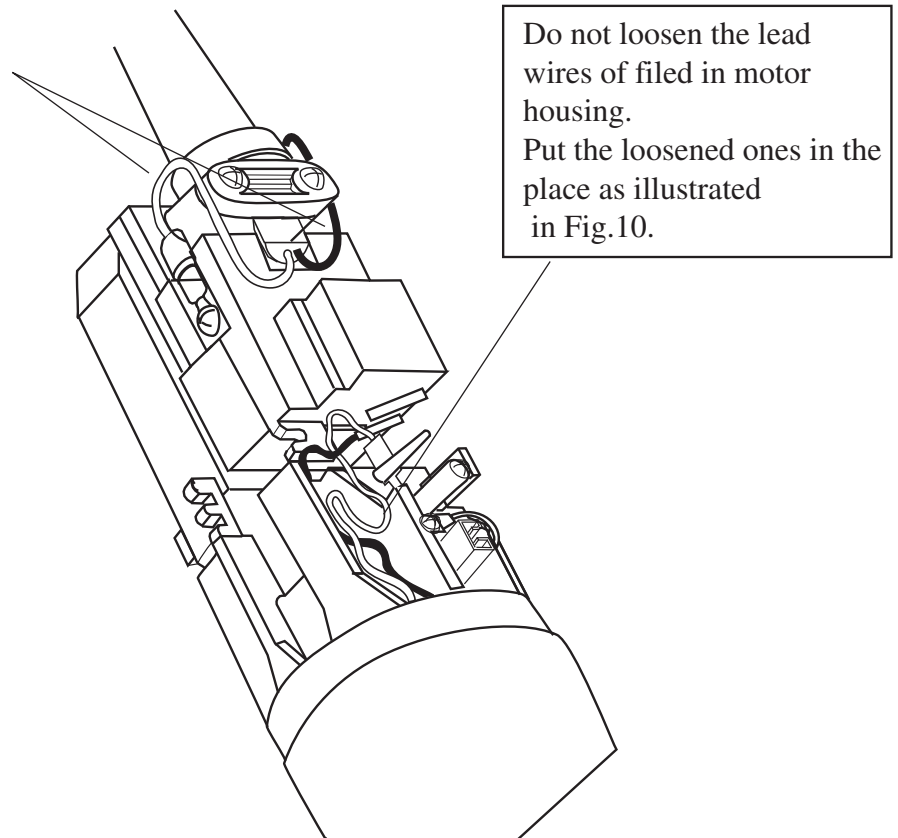

Fig. 10

Model 9561 / Model 9564
without electronic features
with EMC unit

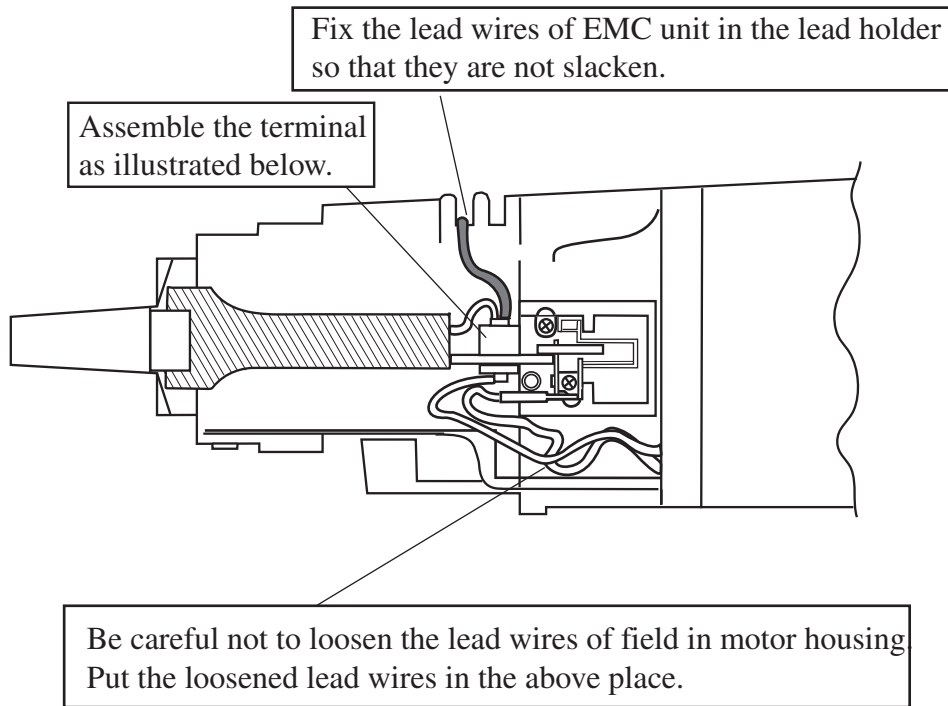

Fig. 11

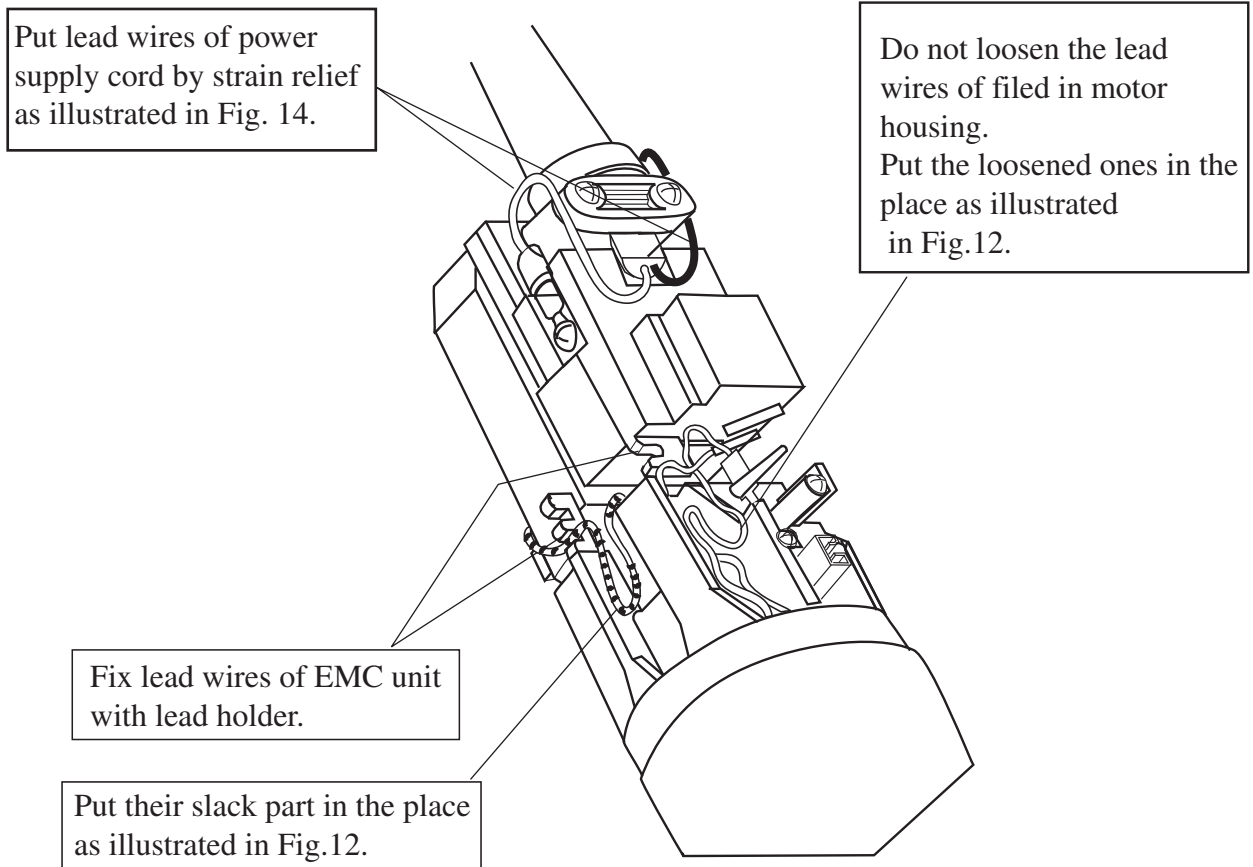

Fig. 12