

T ECHNICAL INFORMATION

Models No. ▶ DC7112

Description ▶ MAKITA Battery charger

CONCEPTION AND MAIN APPLICATIONS

DC7112 is the model modified from the DC7012 based on housing of DC7100.

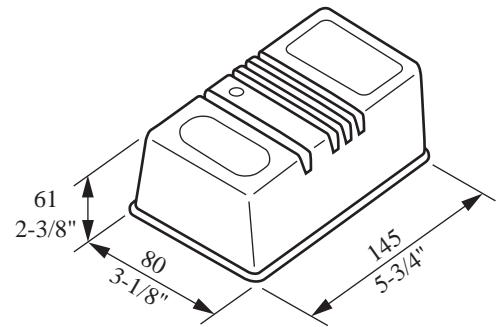

▶ Specifications

Input voltage	DC 12V
Input	18W
Output voltage	DC 7.2V
Output current	DC 1.5A
Charging time	60min
Weight(kg)	0.24Kg(0.53lbs)
Cord length(m)	2m(6.6ft)

▶ Standard equipment

None

▶ Optional accessories

None

▶ Features and benefits

Power source is the inlet of cigarette lighter in the car.