

TECHNICAL INFORMATION



NEW TOOL

P 1 / 5

Models No. ▶ ML123

Description ▶ Rechargeable Job Site Light

CONCEPTION AND MAIN APPLICATIONS

This product has been developed as a sister model of ML122.

It is different from ML122 in the following points.

* Retractable hook instead of strap with hook

* Built in type reflector instead of removable one

The continuous illumination time is 230 minutes (almost 4 hours), if the full charged Ni-MH battery of 3.0Ah is attached to this product.

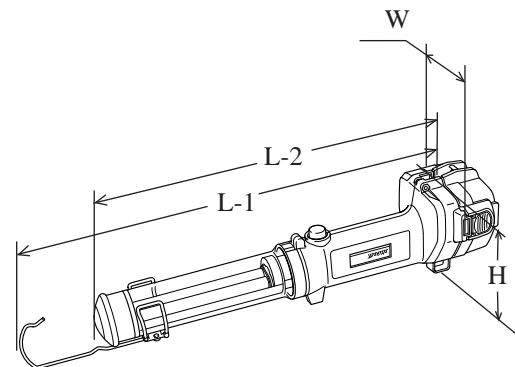

Dimensions : mm (")	
Length (L-1)	411 (16-1/4)
Length (L-2)	350 (13-3/4)
Height (H)	94 (3-11/16)
Width (W)	97 (13-13/16)

< Note > The battery's size is not included in the above dimensions.

Specification

	Battery voltage (V)		9.6	
	12			
Battery capacity (Ah)	3.0	2.0	3.0	2.0
*Continuous illumination time: approx.min.	230	150	230	150
**Illumination (lx)	330		280	
Net weight w/o battery :Kg (lbs)	0.37 (0.82)			

< Note > * Continuous illumination time: The figures shown in the above list can differ from condition to condition of batteries or room temperature.

**Illumination (lx) : The figures shown in the above list were measured on the following conditions.

* With attaching reflector to the product

* Measured at the point of 50 cm distant from light source

Standard equipment

* Set plate 1 pc.

* Hook 1 pc.

< Note > The standard equipment for the tool shown may differ from country to country.

Optional accessories

* Chargers ; DC1411, DC1801, DC9710, DC9711, DC1470, DC1201
DC1422, DC9700, DC1290

* Ni-Cd / 12V Batteries ; 1222, 1202, 1202A, 1200, 1200A, 1220

* Ni-MH / 12V Batteries ; 1233, 1234, 1235, 1235A, 1200A, 1220

* Ni-Cd / 9.6V Batteries ; 9122, 9102, 9102A, 9100, 9120

* Ni-MH / 9.6V Batteries ; 9133, 9134, 9135, 9135A,

► **Features and benefits**

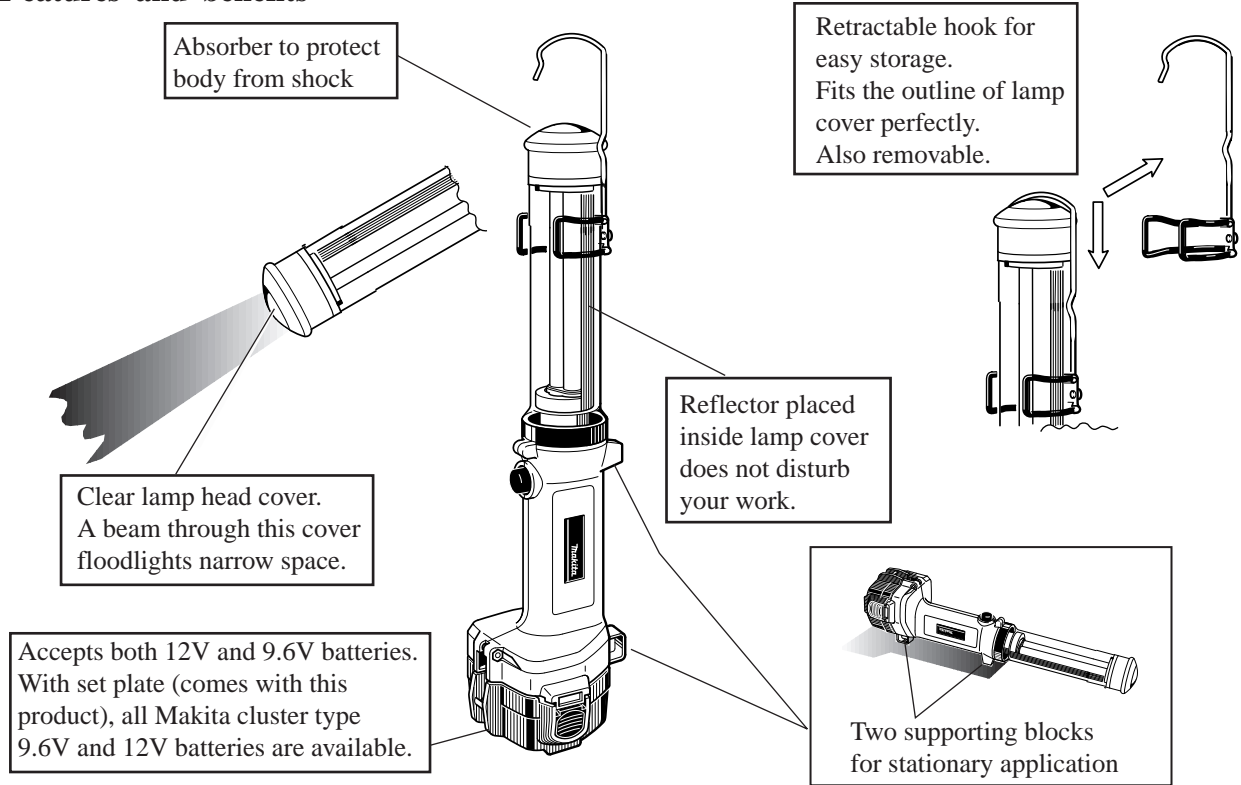

► **Comparison of products**

Specifications		Model No.	MAKITA	
			ML123	ML701
Voltage (V)			9.6 / 12	7.2
*Continuous illumination time: approx.min.	12V/ 2.0Ah		150	120 (with battery 7.2V 1.3Ah)
	9.6V/ 2.0Ah		150	
**Illumination (lx)	12V		330	100 (with battery 7.2V 1.3Ah)
	9.6V		280	
Fluorescent tube	Type of tube		Compact fluorescent tube 13W x 2	Fluorescent tube 4W x 1
	*** Service life : h		2,600	1,000
	Color temperature : K		4,100	4,200
	Starter		No	No
Dimensions : mm (") w/o battery	Length w. hook		411 (16-1/4)	
	Length w/o hook		350 (13-3/4)	210 (8-1/4)
	Width		97 (3-13/16)	44 (1-3/4)
	Height		94 (3-11/16)	91 (3-5/8)
Net weight w/o battery :Kg (lbs)			0.37 (0.82)	0.23 (0.51)
Weight w/ battery 1222 :Kg (lbs)			1.02 (2.25)	
Weight w/ battery 9122 :Kg (lbs)			0.92 (2.03)	0.57 (1.26) w/ battery 7000

< Note > * Continuous illumination time: The figures shown in the above list can differ from condition to condition of batteries or room temperature.

** Illumination (lx) : The figures shown in the above list were measured at the point of 50 cm (19-3/4") distant from light source

*** Service life : The figures shown in the above list are based on the aggregate sum of illumination time in repeating "ON" for 19 minutes and "OFF" for 1 minute

< 1 > Replacing battery holder, switch and circuit complete

(1) Connecting lead wires

The lead wires have to be connected as illustrated in Fig. 1. And then, solder them.

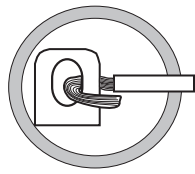

Correct connection

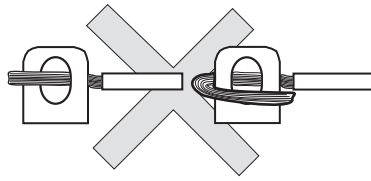

Wrong connection

Fig. 1

Fig. 1A

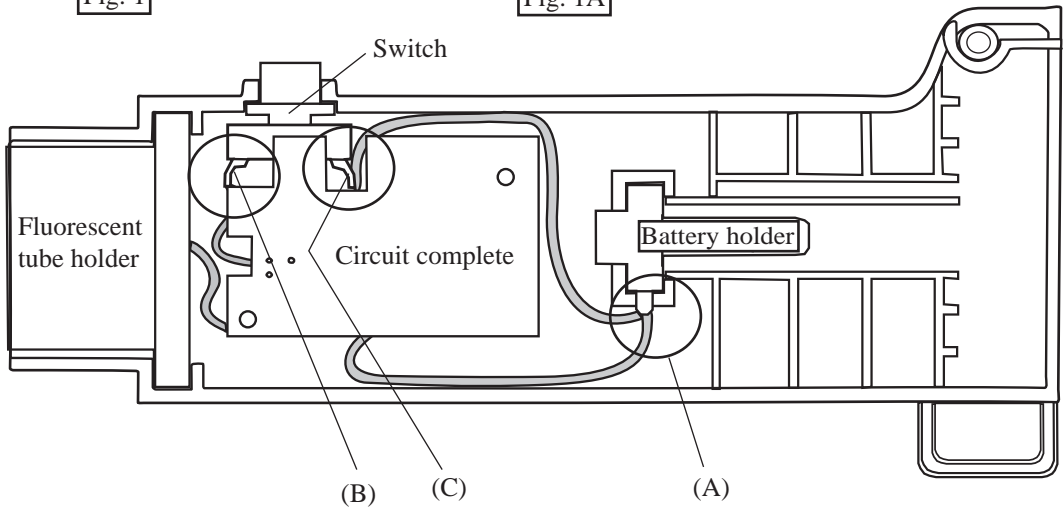

(A) Connecting circuit complete's lead wire with battery holder

Lead wire (black) covered with yellow tube

Yellow tube

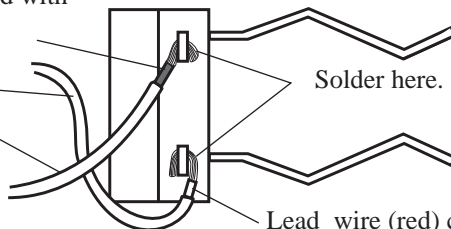

Lead wire (red) covered with yellow tube

(B) (C) Connecting circuit complete's lead wire with switch

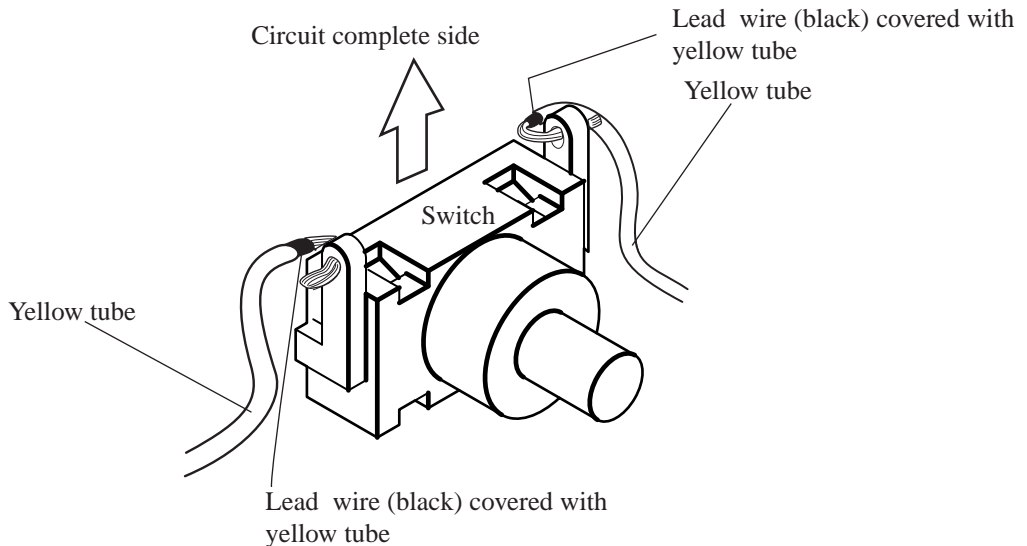

(D-1) Removing circuit complete's lead wire from fluorescent tube holder
Insert small screwdriver deep into rib 1 and 2 and pull out the lead wires pressing with the screwdriver in the direction of the arrow as illustrated in Fig. 2A.

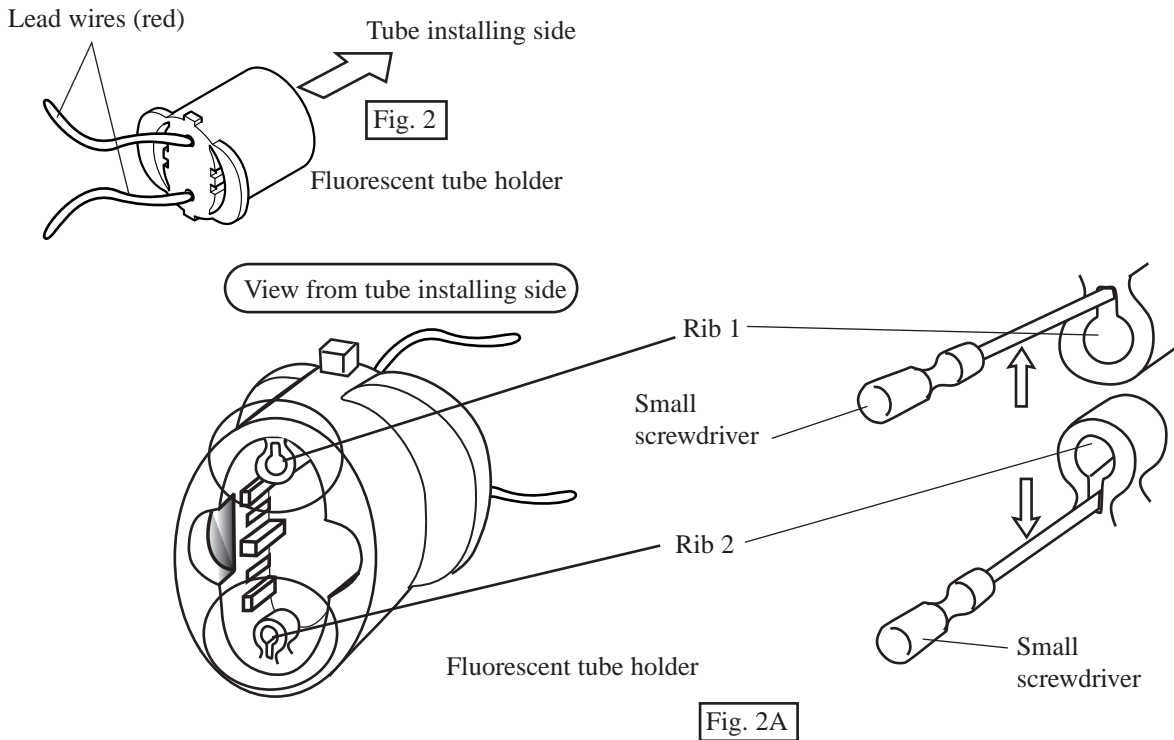

(D-2) Connecting circuit complete's lead wire with fluorescent tube holder
Insert receptacles into the holes of fluorescent tube holder with facing the receptacles' spikes to the outside as illustrated in Fig. 3.

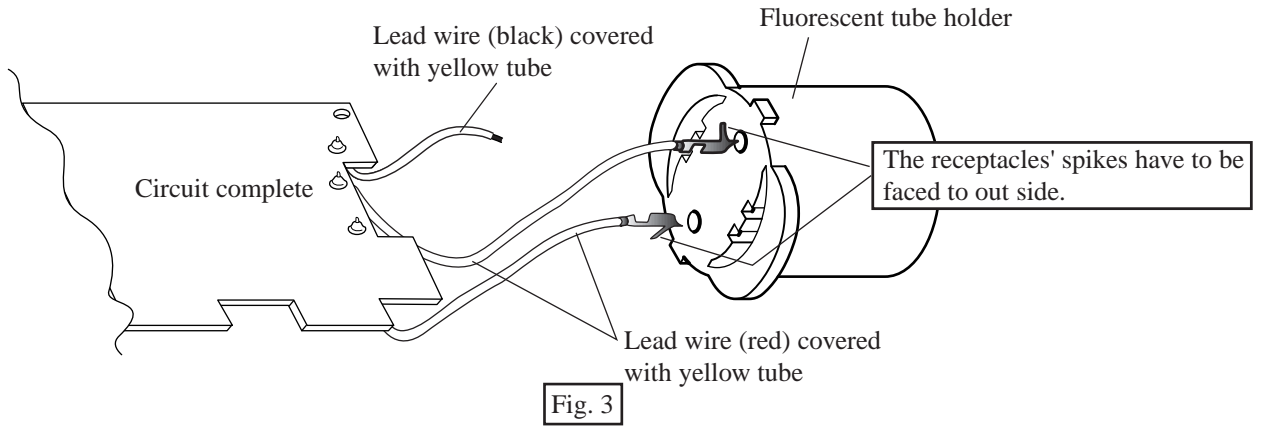

< Note > The spikes of pulled (used) receptacles are deformed as illustrated in Fig. 3A.
The used ones have to be corrected as illustrated in Fig. 3B.

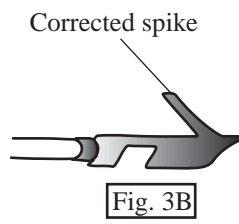
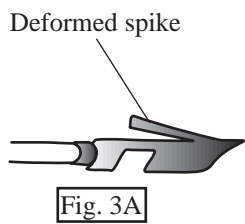

► **Circuit diagram**

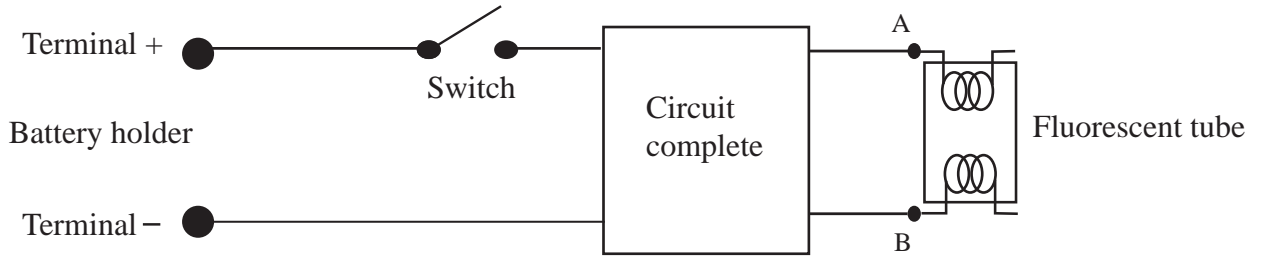

► **Wiring diagram**

