

Triplex Plunger Pump, 1" Hollow Shaft, Nickel-Plated, Gas

FEATURES

- 1" Hollow Shaft, Flanged for Gas Engines
- New forged brass (nickel-plated) manifold, increases working pressure to 4,000 PSI
- New plunger guide bushing (patent pending)
- Solid ceramic plungers with dual guide system
- New optimized outlet valves
- Exclusive protection chamber between crankcase and manifold
- New dual lip oil seal



SPECIFICATIONS

Pump Model	ESN1310G	ESN1313G	ESN1510G	ESN1512G
Maximum Volume	3.43 GPM	3.96 GPM	4.49 GPM	5.28 GPM
Maximum Discharge Pressure	4,000 PSI		3,625 PSI	
Horsepower	9.8 EBHP	11.5 EBHP	8.4 EBHP	9.7 EBHP
Maximum Pump Speed	3400 RPM			
Maximum Inlet Pressure	125 PSI			
Plunger Bore (in / mm)	.512 in./13 mm		.591 in./15 mm	
Plunger Stroke (in / mm)	.394 in./10 mm	.512 in./13 mm	.394 in./10 mm	.472 in./12 mm
Oil Capacity	22 oz. (.65 liters)			
Maximum Fluid Temperature	165° F			
Inlet Port Thread	1/2"-14 BSP-F			
Discharge Port Thread	3/8"-19 BSP-F			
Shaft Diameter	1 in./25.4 mm			
Weight	21 lbs.			
Dimensions - Nominal	10.4" x 10.3" x 4.8"			

TRIPLEX

TRIPLEX



General Pump
is a member of
the Interpump Group

Ref 300953 Rev.A
08-14



Instructions and *ESN Series Pumps*

Maximum temperature of the water through the pump is 165°F (73°C).

In order to obtain maximum performance in terms of duration of seals and valves, it is necessary to respect a few simple rules, as follows:

1) **In order to avoid damage caused by cavitation, the pump must be pressure fed.**

The higher the inlet pressure, the longer the life of the wet end of the pump.

When working at 165°F (73°C), the minimum feed pressure - measured directly in the inlet port of the pump when it is working - is 45 psi (3 bar).

The minimum feed pressure according to the different temperatures are:

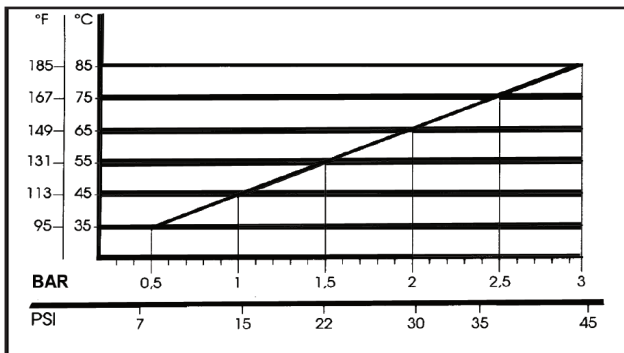

Naturally, if the application allows for feeding the pump with 45 psi (3 bar) even at low temperatures (for example: 115°F/45°C the life of the wet end of the pump will be even longer.

2) **The plumbing which feeds the pump must be of a diameter at least equal to the inlet port.**

Also, follow the suggestions below:

a) Make the plumbing as short and straight as possible, preferably in an upward direction to facilitate the expulsion of eventual air bubbles naturally if compatible with the requirements of the system.

b) It is always useful to put a filter at the inlet with capacity of 4 to 5 times the flow of

the pump, for example for a 4 gpm (15 l/min) pump, put a filter from 16 to 20 gpm (60-75 l/min). The mesh size suitable for this application is 0.016" (.4 mm).

c) It is extremely important to put a pressure switch on the suction port of the pump, and in any case downstream from the filter, so that it can stop the pump should the feed pressure drop by 20% due to the filter clogging or failure of the feed pump, etc.

3) **Change of oil**

We recommend the **first oil change after the first 50 hours**, with the **pump stopped** and the **oil still warm**.

This change is not recommended because the oil has lost its properties, but rather to eliminate the impurities that have gotten into the oil during the running-in phase. If these impurities are not removed, but are allowed to remain in the oil, they *may cause premature wear* to the moving parts and the oil seals. **After this initial change, the oil can then be changed every three months or 300 hours of operation thereafter.**

Please note: If the pump works in conditions with high humidity and with sharp temperature changes, it is possible that condensation will appear inside the crankcase, which mixing with the oil can change its properties. This is easy to see because the oil changes to a white, milky color.

If the pump does not have excessive water leaking from the packings, and the oil becomes milky, the oil has to be changed more frequently. The percentage of water in the oil must not exceed 20%.

Use oil per the following chart:

CHART OF COMPATIBLE OILS SAE15W40	
General Pump	Series 100
BP	VISCO 2000
CASTROL	CWX
MOBIL	SUPER
SHELL	HELIX SUPER
TOTAL	QUARTZ 4000-5000

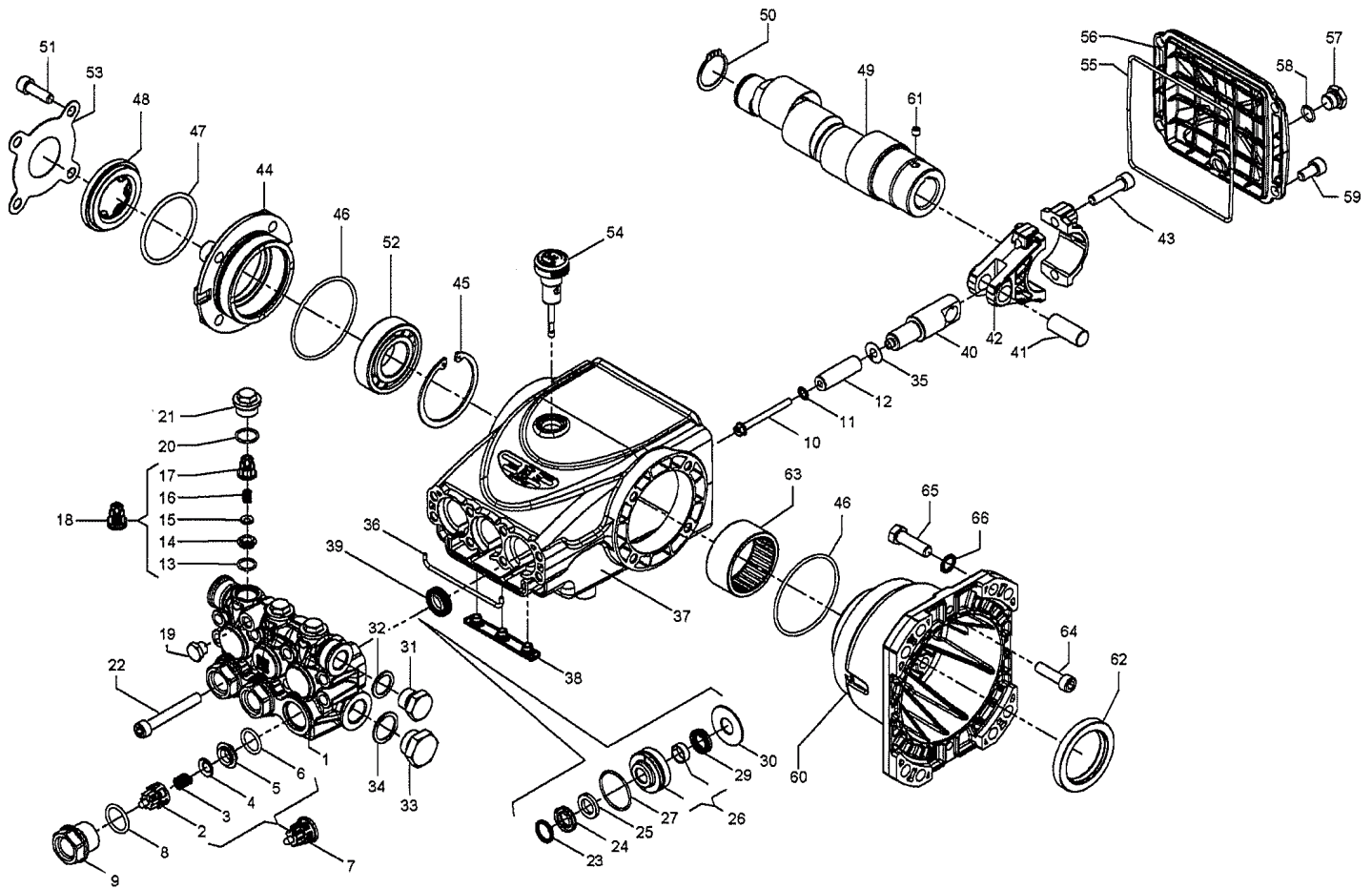

PARTS LIST

ITEM	PART NO.	DESCRIPTION	QTY	ITEM	PART NO.	DESCRIPTION	QTY	ITEM	PART NO.	DESCRIPTION	QTY
1.	59121041	Manifold, Ø 13	1	24.	90261100	Packing, Ø 15, HP	3	45.	90085000	Ring, Seeger, Ø 62	1
	59121141	Manifold, Ø 15	1		90260200	Packing, Ø 13, HP	3	46.	90391300	O-ring, 67.95x2.62	1
2.	36202551	Valve Cage	3	25.	90507650	Anti-ext. Ring, Ø 13	3	47.	90409700	O-ring, Ø 55.56x3.53	1
3.	94767600	Spring, Ø 9.4x14.8	3		90508990	Anti-ext. Ring, Ø 15	3	48.	44211801	Sight Glass	1
4.	36200176	Valve, Spherical	3	26.	59605801	Intermed. Ring, Ø 13	3	49.	59020465	Crankshaft (ESN1313G)	1
5.	36200366	Valve Seat, Inlet	3		59605901	Intermed. Ring, Ø 15	3		59020565	Crankshaft (ESN1512G)	1
6.	701115	O-ring, Ø17.13x2.62	3	27.	90361200	O-ring, 31.47x1.78	3		59020665	Crankshaft, (ESN1510G, ESN1310G)	1
7.	36711501	Valve Assembly	3	29.	90260800	Seal, Ø 15, LP	3	50.	90066700	Retaining Clip	1
8.	701002	O-ring, Ø20.24x2.62	3		90260100	Seal, Ø 13, LP	3	51.	99306900	Screw, M8x25	4
9.	98222500	Valve Cap, M24x1.5x16.7	3	30.	59210570	Support Ring, Ø 13	3	52.	91837600	Tapered Roller Bearing	1
10.	99169000	Plunger Bolt, M5x55	3		59210670	Support Ring, Ø 15	3	53.	66150274	Cover	1
11.	99690500	Washer, Ø 5x11.5x0.4	3	31.	98209900	Plug, 3/8"x13, Nickel	1	54.	98210500	Oil Dipstick	1
12.	58040009	Plunger, Ø 13x42	3	32.	96738000	Gasket, 17.5x23x1.5	1	55.	90392200	O-ring, Ø133.02x2.62	1
	58040109	Plunger, Ø 15x42	3	33.	98217900	Plug, 1/2" BSPx10, Nickel	1	56.	59160022	Rear Cover	1
13.	701014	O-ring, Ø 12.42x1.78	3	34.	96751400	Gasket, Ø 21.5x27x1.5	1	57.	98204250	Plug, 1/4"x9	1
14.	36211366	Outlet Valve Seat	3	35.	96699000	Washer, Ø 7.5x23x0.5	3	58.	701013	O-ring, Ø 10.82x1.78	1
15.	36211276	Outlet Valve Poppet	3	36.	59211082	Gasket, Ø 3x103	1	59.	99303900	Screw, M8x16	4
16.	94733300	Spring, Ø 6.2x10.4	3	37.	59010022	Crankcase	1	60.	10080122	Motor Flange	1
17.	36211151	Outlet Valve Cage Guide	3	38.	58210451	Drip Cover	1	61.	99179000	Screw, M6x6	1
18.	36719301	Complete Outlet Valve	3	39.	90156550	Oil Seal, Ø 15x24x5.7	3	62.	90169000	Oil Seal, Ø45x62x8	1
19.	98196700	Plug, Nickel	3	40.	59050066	Piston Guide	3	63.	91858500	Bearing, Needle	1
20.	701016	O-ring, Ø 15.6x1.78	3	41.	97739900	Piston Pin, Ø 14x34	3	64.	90308400	Screw, M8x30	4
21.	98213750	Outlet Valve Cap, M18x1.5x10	3	42.	59030001	Connecting Rod	3	65.	99334600	Screw, 3/8"-16x1-1/4"	4
22.	99317500	Screw, M8x60	8	43.	99309900	Connecting Rod Screw	6	66.	96710400	Washer, Ø 10.5x16x1	4
23.	63101051	Head Ring, Ø 15	3	44.	47150022	Crankcase Cover, Side	1				
	44100251	Head Ring, Ø 13	3								

REPAIR KITS

KIT NO.	K269	K292	K271	Ø 13		Ø 15	
				K282	K287	K283	K288
ITEM NO'S INCLUDED IN KIT	2, 3, 4, 5, 6, 13, 14, 15, 16, 17, (7), (18)	8, 9, 20, 21	39	23, 24, 25, 27, 29	23, 24, 25, 26, 27, 29, 30	23, 24, 25, 27, 29	23, 24, 25, 26, 27, 29, 30
NUMBER OF ASSY'S IN KIT	6	6	3	3	1	3	1
NO. OF CYLINDERS KIT SERVICES	3	3	3	3	1	3	1

TORQUE SPECS*

Position	Ft.-Lbs.	Nm.
9	96	130
10	4.5	6
19*	9.6	13
21	26	35
22	14.8	20
31	30	40
33	30	40
43	14.8	20
51	14.8	20
57	14.8	20
59	14.8	20
64	14.8	20

*Use Loctite 542 Red

DIMENSIONS

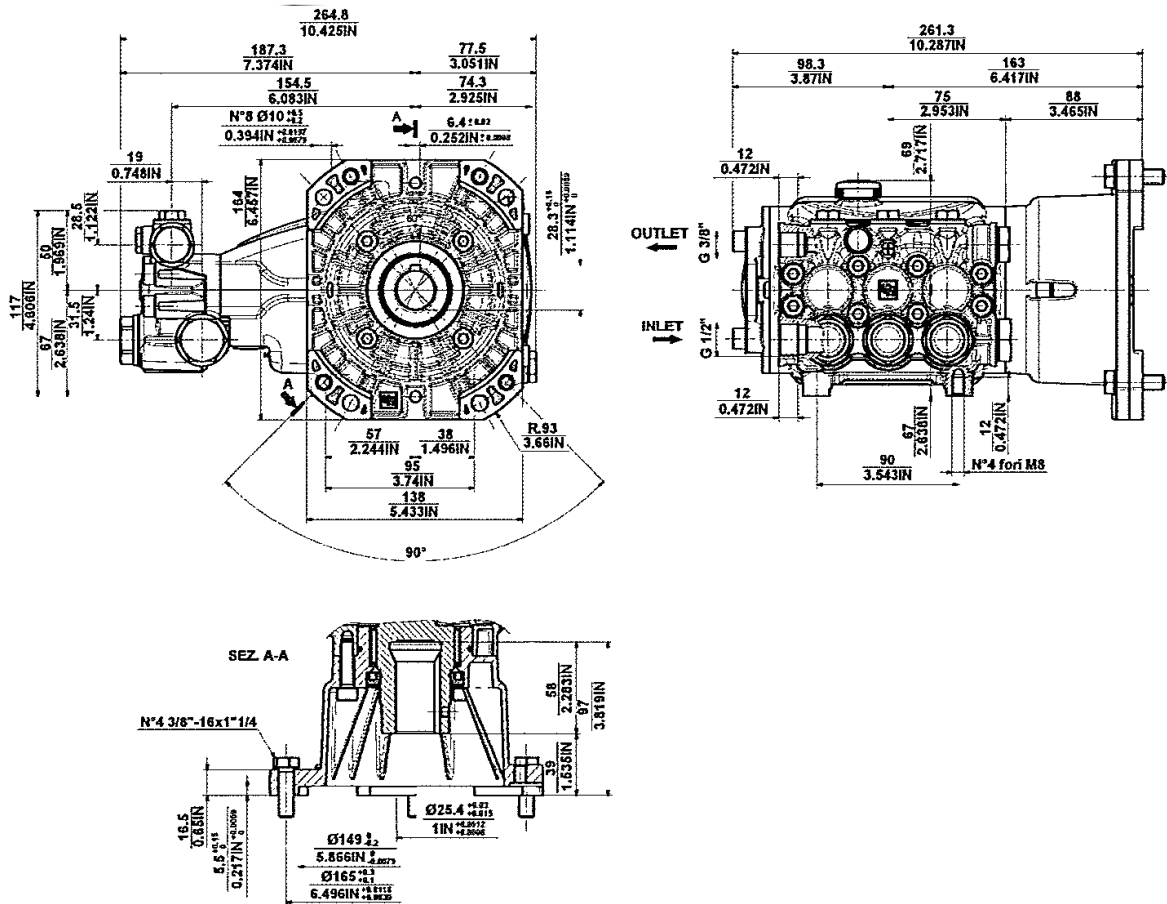

Ref 300953 Rev.A
08-14

