

FEATURES

- Compensated pressure regulating valve
- Central body and fittings in brass
- Regulates the bypass of fluid with a minimum variation in pressure
- Easy Maintenance
- Suitable to be used as a safety valve

General Pump recommends using a safety relief device in conjunction with this unloader valve when installed on a positive displacement pump. General Pump is not liable and assumes no responsibility when used in a customer's high pressure system.

SPECIFICATIONS

Part Number	YVS5100B
Maximum Temperature	195 ^o F1
Max. Volume	6.6 GPM
Rated Pressure	5,100 PSI
Minimum Adjustable Pressure.....	500 PSI
Maximum Discharge Pressure	5,600 PSI
Pressure Increase.....	500 PSI ²
Port Sizes: Inlet.....	3/8" BSP-F
Bypass	3/8" BSP-F
Overall Dimensions	5.22" x 1.87" x 1.18"
Weight	1.3 lbs.
Materials	Brass Body, Stainless Steel

1 This unloader has been designed to operate at a continuous water temperature of 140°F. It can be operated for short periods at a maximum temperature of 195°F.
2 This is the pressure reduction necessary in comparison to the set up, in order that the valve brings back pressure in the circuit (% figures of the pressure set up).

DIMENSIONS

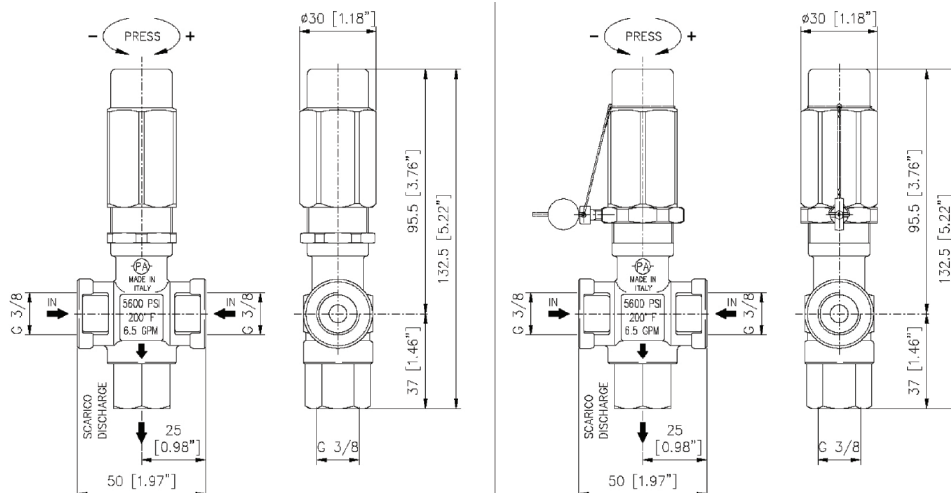

PARTS LIST

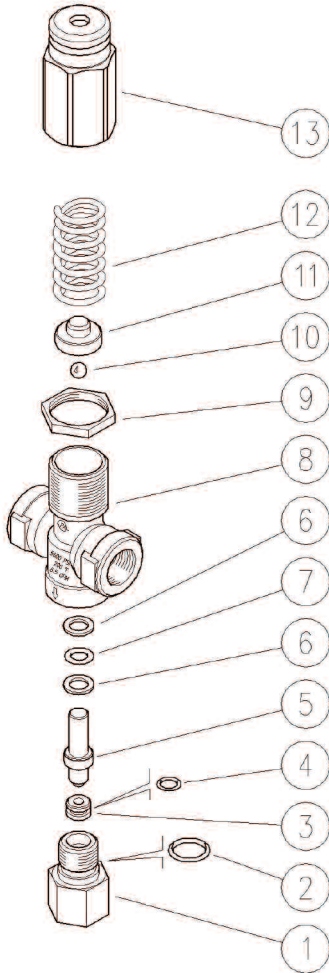

Pos.	Part #	Description	Qty.
1	Y60058531	Seat Holder, 3/8" BSP-F, Brass	1
2*	Y10306401	O-ring, 1.78x14mm	1
3*	Y60058651	Seat, 4.2x10x5, SST	1
4*	Y10305202	O-ring, 1.78x6.75	1
5	Y60058723	Piston, SST + Ball, 7/32", SST	1
6*	Y10402000	Back-up Ring, 8x12.6x1.2	2
7*	Y10317008	O-ring, 2.62x7.6	1
8	Y60058135	Valve Housing, Brass	1
9	Y60052331	Ring Nut, M24x1.25, Brass	1
10	Y14742150	Ball, 1/4", SST	1
11	Y60058331	Spring Guide Spacer, Brass	1
12	Y60058461	Spring, 4.2x18.4x56	1
13	Y60053231	Valve Regulating Knob, M24 Brass	1
*	YKITVS5100	Repair Kit	

INSTRUCTIONS

SELECTION

This product is to be used with clean water which can contain the addition of normal detergents. For use involving different or corrosive liquids, contact the General Pump Customer Service Department. Appropriate filtration should be installed when using water that may contain any sort of debris. Choose the valve appropriate for the system rated pressure, maximum flow rate and maximum temperature. In any case, the pressure of the machine should not exceed the permissible pressure rate imprinted on the valve.

INSTALLATION

On a system that produces hot water, this accessory must be fitted upstream of the heat generator. On a system that generates hot water, it is advisable to fit in accessories that limit the accidental increase of fluid temperature.

ALWAYS INSTALL A SAFETY VALVE

It is recommended to use a nozzle with a size that, at gun opened, allows to discharge from the valve bypass at least 5% of the flow supplied by the pump in order to obtain a constant pressure value, and an easy adjustment and to avoid troublesome pressure spikes at gun closure.

If the nozzle wears out, the working pressure decreases. To reset the pressure back to work level, it is necessary to replace the worn nozzle. When a new nozzle is fitted, re-setting of the system to its original working pressure is necessary.

INSTRUCTIONS (cont.)**DISCHARGE SYSTEM AND WATER ADDUCTION**

We recommend to fit the valve with the bypass discharge returned to a tank. It is advisable that the tank be fitted with baffles to reduce eventual turbulence and air bubbles generated by the emission of the bypass flow which could be harmful for the pump. With elevated flow or near to the maximum flow of the valve, the installation with a recirculation of bypass direct to the pump could cause potential pressure spikes harmful to the pump.

PRESSURE ADJUSTMENT/CALIBRATION

The desired working pressure must be adjusted with the system running and the gun opened. Adjust the pressure by screwing or unscrewing the adjustment screw/knob. The operation is easier if the correct nozzle has been chosen (see paragraph "installation"). When screwing the screw/knob a consequent pressure increase must be matched. If, before reaching the desired pressure, there is no pressure increase when screwing the screw/knob, do not force but check the correct relation nozzle/flow rate - pressure and, if necessary, fit a nozzle with a smaller size.

TROUBLESHOOTING

PROBLEMS	PROBABLE CAUSES	SOLUTIONS
Frequent Unloader Cycles	Damaged check valve o-ring Leaking connections Restricted bypass	Replace Check and renew Clean or adapt
Unloader does not come up to pressure	Unloader not properly sized Piston O-rings worn out Debris between seat and shutter Worn nozzle	Change spring or type of valve Replace Clean the seat Replace
Excessive pressure spikes	There is not a minimum of 5% flow in bypass Excessive flow in bypass Spring totally compressed	Reset Change type of valve or adjust passages Loosen knob and change nozzle
Unloader does not bypass at low pressure	Jammed check valve Check valve O-ring worn Debris in check valve	Clean or replace Replace Clean

MAINTENANCE

Maintenance must be carried out by Qualified Technicians.

STANDARD: Every 400 working hours (10,000 cycles), check and lubricate the seals with water resistant grease.

SPECIAL: Every 800 working hours (20,000 cycles), check the wear of the seals and internal parts and, if necessary, replace with original General Pump parts taking care during installation and to lubricate with water resistant grease.

The manufacturer is not responsible for damage as a result of incorrect fitting and maintenance.